



Air Tracker 6000

Air-Flow Monitoring System

General

The Air Tracker 6000 air-flow monitoring system was developed in response to requests from commercial and industrial system design engineers, equipment OEMs, and facility end-users for an accurate, cost effective method of measuring air flow in their HVAC and industrial-process systems. They also wanted to avoid costly field installation as well as any degradation in air-flow and sound, typical of conventional “in-the-air-stream” Piezometer ring measuring systems. After extensive modeling and testing at the nyb research center and laboratory, the Air Tracker 6000 was developed to meet these requirements.

The air measurement side of the system is installed and piped at the factory using skilled craftsmen, documented designs, and established quality procedures. There are no tubes or probes in the active air stream to reduce air flow or create air turbulence noise.

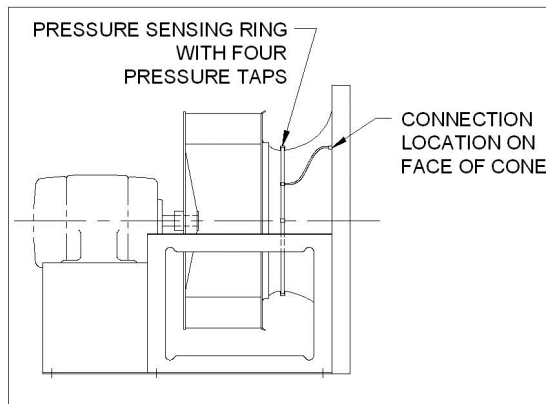

Air Tracker 6000 Air Movement

The optional Air Tracker 6000 microprocessor is a Dwyer DHII controller and is selected at the factory and programmed for the pressure range of the system being monitored and arrives at the job site preprogrammed specifically for each fan. Field installation is simple and consists of mounting the controller, connecting the two pressure taps, and wiring to either a 120 volt, 240 volt, or a 24 VDC power source.

The air measuring portion of the system can be used in conjunction with other processing and display systems as long as they have square-root computational capability. If the optional Dwyer DHII microprocessor based controller is used, the system can also trigger alarms, or in conjunction with variable speed drives and/or a building management system, can be used in a control loop to modify system air flow based on system requirements via the 4 - 20 mA and serial communication outputs.

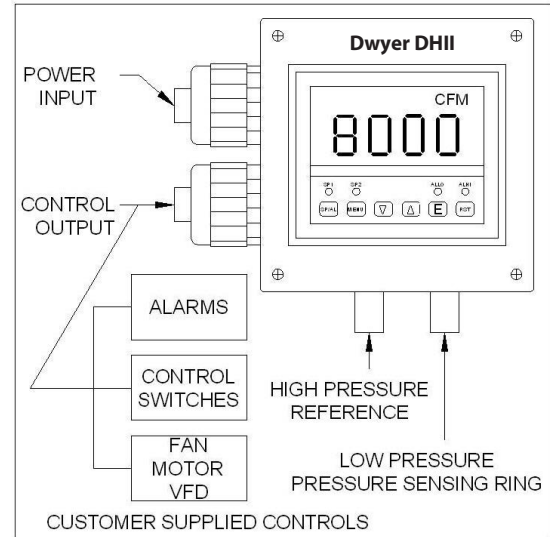

Air Tracker 6000 Air Controller

APPLICATIONS

The Air Tracker 6000 is available on all nyb air handling fans that utilize conventional or AcF-q inlet cones. For example: ACF/PLR/BC Single-Width Fans, Double-Width Fans, Plenum Fans, Plug Fans, AF Series Fans, and others. The air stream must be relatively clean (no material handling fans) and dry.

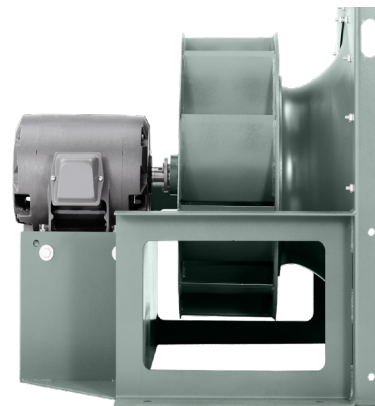

Typical Arrangement 4 Plenum Fan



For more information about other air monitoring devices, visit <https://www.nyb.com/fan-sensor-systems/>.