

SERIES 45 GI FANS

WITH RUGGED RADIAL-BLADE WHEELS



- Capacities to 100,000 CFM
- Static pressures to 46"WG
- Temperatures to 1000°F.



SERIES 20 GI FANS

- Capacities to 77,000 CFM
- Static pressures to 22"WG



SERIES 30 GI FANS

- Capacities to 95,000 CFM
- Static pressures to 32"WG



COMPACT GI FANS

- Capacities to 2,200 CFM
- Static pressures to 14"WG



THE NEW YORK BLOWER COMPANY
7660 Quincy Street
Willowbrook, IL 60527-5530

Visit us on the Web: <http://www.nyb.com>
Phone: (800) 208-7918 Email: nyb@nyb.com

SERIES 45 GI FANS

...for industrial air-moving and material-handling applications

This bulletin covers only Series 45 GI Fans, one of four **nyb** radial-blade fan lines which cover a wide range of performance and application requirements. The design parameters and standard features of Series 45 GI Fans are listed below.

- 22" through 85" wheel diameters
- 13" to 49" inlet diameters
- Up to 46" static pressure
- Capacities to 100,000 CFM
- Temperatures to 1000°F.



Size 364
Arrangement 1
Series 45 GI Fan

AIR MOVING APPLICATIONS

- Pollution control
- Pneumatic conveying
- Oven and dryer exhaust
- Fluidizing fans
- Combustion air
- Kiln exhaust

TYPICAL USER INDUSTRIES

- Chemical industry
- Pulp and paper
- Forest products
- Petrochemical
- Food processing
- Pharmaceutical
- Primary metals
- Printing

STANDARD FEATURES

Welded construction—provides rigidity for rugged industrial applications. Sizes 224 through 294 welded housings and bases are bolted together. These sizes can be rotated to other discharge positions if required.

Lifting eyes—on all sizes for ease of handling.

Flanged inlets and flanged outlets—with holes on all sizes [see page 13 for standard hole locations].

Bearings—ball or spherical roller bearings selected for extended service life over operating range [see page 13 for size and type].

Shafting—turned, ground, and polished shafting is straightened to close tolerance to minimize “run out” and ensure smooth operation.

Precision balancing—Series 45 GI Fan wheels are dynamically balanced before final assembly, all fans are fine-tune balanced at as-ordered operating speeds.

Shaft seal—ceramic-felt shaft seals are standard...multiple-seal elements compressed between metal backing plate and retainer...elements can be easily split for field replacement.

OPTIONAL FEATURES

Belt drive or direct drive—Fans are available in Arrangement 1 and 8. For direct drive, special wheel construction is used to match the performance requirements with motor speeds.

Inlet box—bolt-on type inlet box available on all sizes.

Dampers—three types: inlet-box damper, inlet damper, and outlet damper [see page 4].

Split housings—to allow access to the wheel with minimal duct removal required.

Heat fan construction—special design allows for airstream temperatures up to 800°F. for DH wheels and 1000°F. for LS and RIM wheels [see page 5].

Abrasion resistance—special design of LS and RIM wheels provides material-handling abrasion resistance [see page 5].

Spark-resistant construction—three types of special construction available for all sizes [see page 5].

Copyright © 2011 by The New York Blower Company.
® Registered trademark of The New York Blower Company.

CHOICE OF TWO WHEEL DESIGNS



DH WHEEL

Available in Sizes 224 through 854.

Unique, high-efficiency radial wheel utilizes curved blades and a tapered frontplate to minimize turbulence and control flow through the wheel. Can be used for airstreams with moderate dust loads that do not contain large particles or wet, sticky materials. Performance is stable from wide-open to completely closed-off.



LS/RIM WHEEL

LS Wheel – Sizes 224 through 364.

RIM Wheel – Size 404 through 854.

Rugged, radial-blade design best for material-conveying applications with airstreams that contain coarse material or heavy dust and particulate matter. As with the DH wheel, the LS wheel provides stable airflow performance over the entire pressure range, from wide-open to completely closed-off.

ARRANGEMENTS AND DRIVE METHODS

Series 45 GI Fans are available in Arrangement 8 with wheel and housing modifications to accommodate required performance at direct drive motor or turbine speed. Refer to separate **nyb** Engineering Supplement for details on how to select special width LS and RIM designs.

Arrangement 8 construction includes driver sub-base integrated with fan bearing pedestal providing a unitary package in which driver is direct-coupled to the fan shaft with a flexible coupling.

Arrangement 1 construction can also be used for direct drive by providing a separate motor base [by others] in the field.

Standard fan construction is good for temperatures to 300°F. For higher temperatures, see page 6.

AMCA STANDARD MOTOR POSITIONS

Motor positions are independent of fan rotation and discharge positions and are determined by viewing fan from drive end.

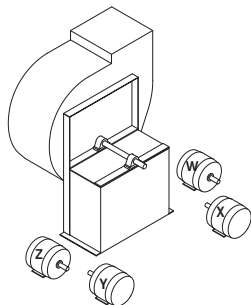

Arrangement 1 fans are used most frequently for V-belt drive installations. Standard fan construction is good for temperatures to 300°F. For higher temperatures, see page 6.

In the lower horsepower ranges, V-belt drive selection is relatively simple, but as horsepower requirements increase, V-belt drive selection becomes more complicated and requires more consideration of the drive's effect on fan and motor bearings.

For higher horsepower V-belt drive applications, consult **nyb**.

Although there are exceptions to every rule, there are a few general recommendations to remember.

1. 3600 RPM motors are not generally recommended for a belt drive above 20 HP.
2. 1800 RPM motors are not generally recommended for a belt drive above 300 HP.
3. When motors 125 HP and larger are to be used with belt driven fans, **nyb** requires that the motor manufacturer:
 - a. Recommend the minimum diameter motor sheave that may be used.
 - b. Recommend the maximum motor sheave width that may be used.

With the above information from the motor manufacturer, the drive may be selected. All customer-supplied drives over 300 HP require approval from **nyb**.

ACCESSORIES

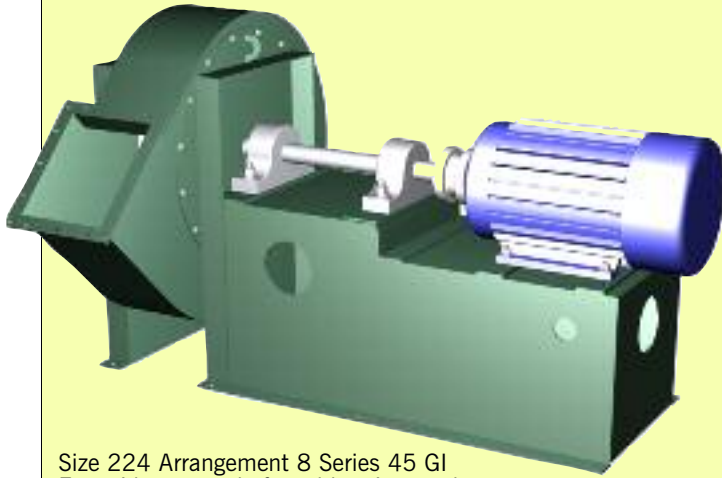

Size 224 Arrangement 8 Series 45 GI Fan with motor, shaft and bearing, and flanged outlet.

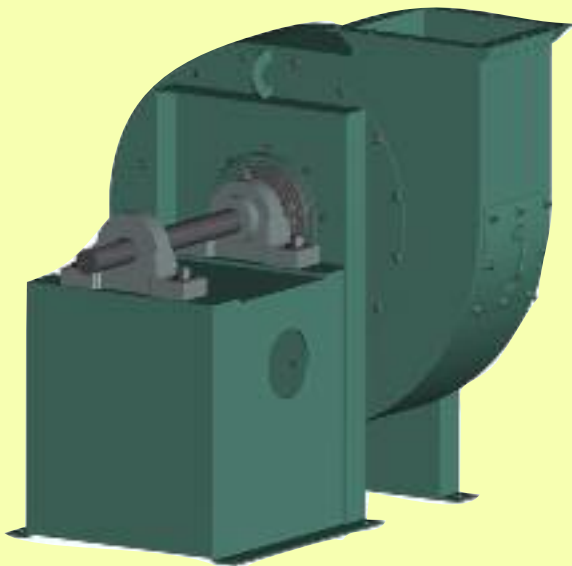

Size 224 Arrangement 1 Series 45 GI Fan with motor, shaft and bearing, bolted cleanout door, and flanged outlet.

SAFETY EQUIPMENT

Safety accessories are available from **nyb**, but selection of the appropriate devices is the responsibility of the system-designer who is familiar with the particular installation, or application, and can provide for guards for all exposed moving parts as well as protection from access to high-velocity airstreams. Neither **nyb** nor its sales representatives is in a position to make such a determination. Users and/or installers should read "Recommended Safety Practices for Air Moving Devices" as published by the Air Movement and Control Association International, Arlington Heights, Illinois.

- **BELT GUARD, SHAFT GUARD, AND COUPLING GUARD**
See separate **nyb** Safety Equipment Bulletin.

- **CLEANOUT DOOR**

Flush-bolted or raised-bolted doors [to allow for insulation] are available. Located at approximately 3:00 and 9:00 o'clock positions opposite discharge as standard.

- **DRAIN**

1½" threaded tank flange located at lowest point in housing scroll.



- **UNITARY BASE**

Structural steel base provides common support for fan, motor, and drive components...also available with spring-type or rubber-in-shear isolators...flexible duct connections are necessary with isolation bases.

- **INLET BOX AND INLET BOX DAMPER**

Inlet box—an inlet box is often used to accomplish a 90° turn into the fan inlet. A properly designed inlet box will provide minimal and predictable entry losses normally associated with a 90° turn located at the fan inlet...see separate **nyb** Catalog Sheet for details.

Parallel-blade inlet-box damper—spins the air in direction of wheel rotation, providing greater power savings at reduced loads than with outlet dampers. See separate **nyb** Catalog Sheet for details and **nyb** Engineering Letter for damper-selection information.

CAUTION: The use of inlet boxes in material-handling applications is not recommended as the inlet box may act as a settling chamber.

- **EXTERNAL INLET VANE DAMPER**

External vane construction for flange mounting to fan inlet... available for Sizes 294 and larger. The vanes spin the air in direction of wheel rotation, providing greater power savings at reduced loads than with outlet dampers. Recommended for use with DH wheel and with relatively clean airstreams. Maximum temperature: 800°F.

See separate **nyb** Engineering Letter for damper selection information.

- **OUTLET DAMPERS**

Outlet dampers are available for use with all Series 45 GI Fans. Outlet dampers are available with parallel or opposed-blade construction.

Standard outlet-damper construction includes removable linkage and casing side to allow for replacement of bushings, bearings, and vanes. Optional flanged ball bearing or stuffing-box construction allows damper selection to suit the application.

See separate **nyb** Catalog Sheet for complete damper details and **nyb** Engineering Letter for damper-selection information.

- **SPLIT HOUSINGS**

Sizes 334 and larger are available with split housings...bars are welded to housing to permit bolting sections together. Inlet and outlet connections do not have to be removed except the outlet connection must be removed on Up Blast fans.

MODIFICATIONS

ABRASION-RESISTANT CONSTRUCTION

For LS and RIM wheel designs

The following modifications are available to increase service life when fan is subjected to abrasion or erosion from air-borne contaminants.

ASTM A-514 blades—wheel blades fabricated to alloy steel with 321 minimum Brinell hardness.

Checkerplate blades—wheel blades fabricated of four-way floor plate.

Scroll liners—removable liners of ASTM A-514 alloy are bolted to housing interior...split housing required.

HANDLING CORROSIVES

Industrial exhaust and process applications are sometimes more difficult due to the presence of corrosive fumes or particulate. Alternate alloy construction or special paint systems can usually provide some degree of longer life.

Series 45 GI Fans with LS or RIM wheels can be constructed with airstream parts of 304, 316, or 347 stainless steel. 316 stainless steel generally provides the best corrosion resistance of the three types available. However, the effectiveness of any particular alloy can best be judged by the user's experience in his or similar applications.

A separate nyb Engineering Letter provides basic information regarding the different types of coatings that are available for fan equipment. That information may assist the user in determining the specific coating that may serve his purposes. However, nyb cannot guarantee the suitability of a coating for a particular application.

SPARK-RESISTANT CONSTRUCTION

There is no method of construction that can guarantee against the potential of producing sparks in fans. We can only use spark-resistant materials and manufacturing techniques that tend to minimize the potential of two or more components making contact which may produce sparks. Refer to nyb Engineering Letter for additional information and limitations of SRC. The following types of construction are available:

AMCA A [AIRSTREAM] SRC

To include all airstream parts constructed of a spark-resistant alloy...maximum temperature: 200°F.

AMCA B [WHEEL] SRC

To include the fan wheel constructed of a spark-resistant alloy and a buffer plate around the housing shaft-hole opening...maximum temperature: 200°F.

AMCA C [BUFFER] SRC

To include buffer rings adjacent to the wheel front and back, and a buffer plate around the housing shaft-hole opening...maximum temperature: 800°F.

ALL TYPES SRC

Fan must be constructed so that no bearings, drive components, or electrical apparatus are located in the airstream. User must electrically ground all fan and system components. Refer to Engineering Letter 15 for the full meaning and limits of spark-resistant construction.

SPLIT-HOUSING CONSTRUCTION

Sizes 334 and larger are available with split housings...bars are welded to housing to permit bolting sections together. Inlet and outlet connections do not have to be removed except as noted.

TYPE A

**Bottom Horizontal
Up Blast (shown)
Down Blast**

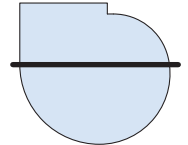

Horizontal split allows removal of top section without disturbing inlet connection...outlet connection must be broken on Up Blast fans only.

TYPE B

**Top Horizontal
Top Angular Down
(shown)
Bottom Angular Up
Top Angular Up**

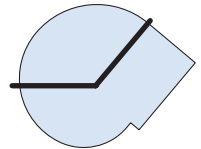

Split allows removal of pie-shaped section without disturbing inlet or outlet connections.

HEAT-FAN CONSTRUCTION

Successful operation of fans at elevated temperatures requires consideration of two main factors.

1. Effect of temperature on wheel maximum safe speeds [see page 6].
2. Effect of air density on aerodynamic performance [see page 6].

Heat fan modifications include shaft coolers and shaft-cooler guards. Standard fan construction also provides a gap between the fan housing and the bearing pedestal that retards the conduction of heat to the bearings. When operating temperature exceeds 300°F, high-temperature paint is furnished.

Series 45 GI heat fans with mild steel LS or RIM wheels or standard high-strength steel DH wheels have a maximum temperature limit of 800°F. LS and RIM wheels can be constructed with A-572-50/60 alloy to maintain standard safe speed limits to 800°F.

Series 45 GI Fans with LS or RIM wheels can be made suitable for 1000°F. operation by providing stainless steel wheels and shafts.

SELECTION OF SERIES 45 GI FANS

The selection of a General Industrial Fan involves consideration of a number of factors. Initially, the type of wheel must be selected. For airstreams with moderate dust loads, the DH wheel is often chosen because of its higher operating efficiency. The LS/RIM wheel is more suited for airstreams containing material and particulate but is not as efficient as the DH wheel.

CORRECTIONS FOR AIRSTREAMS OTHER THAN STANDARD DENSITY [.075 lbs./cu. ft.]

The performance tables on pages 7 through 12 give fan performance based on air at 70°F. at sea level at a density of .075 lbs./cu. ft. If the airstream density is other than .075 lbs./cu. ft., corrections must be made to static pressure and brake horsepower.

CALCULATING FANS AT TEMPERATURES OTHER THAN 70°F.

Chart IV gives factors for correcting pressure and brake horsepower for temperatures other than 70°F.

EXAMPLE:

1. Require 10,000 CFM at 20" SP at 600°F. at sea level.
2. Chart IV indicates a 2.00 factor for 600°F.
3. Select the fan for 40" SP[20" x 2.00] at 70°F.
4. Divide 70°F. brake horsepower by 2.00 to determine BHP at conditions.

CALCULATING FANS AT ALTITUDES OTHER THAN SEA LEVEL [29.92 in. Hg]

Correcting for altitude is the same as for temperature except using the factors in Chart V.

CORRECTION FOR DENSITY RAREFICATION

When negative static pressure exists on the inlet side of a fan, additional correction for a lower density should be made. When negative pressure is less than 20", this factor is usually considered negligible unless the system designer is calculating to extremely close tolerances. Chart VI shows correction factors for negative inlet pressure. The factors apply to static pressure and brake horsepower in the same manner as temperature and altitude corrections.

HANDLING GASES OTHER THAN AIR

Whenever the fan airstream is made up of gases other than standard air, the density of the airstream must be determined for accurate fan selection. In addition to the type of gases in the airstream, the amount of moisture or material in the airstream affects density and needs to be taken into account. Engineering handbook reference is frequently required to calculate the densities in such applications. Consult your **nyb** representative for assistance.

The performance tables on the following pages are based on an airstream at 70°F. at sea level at a density of .075 lbs./cu. ft. When a fan handles other than air at a density of .075 lbs./cu. ft., a correction factor must be considered.

CHART I MAXIMUM SAFE SPEEDS OF DH, LS, AND RIM WHEELS AT 70°F.

Size	Speed
224	3800
264	3600
294	3090
334	2770
364	2500
404	2285
454	2000
504	1810
574	1590
644	1420
714	1280
784	1170
854	1070

CHART II TEMPERATURE CORRECTION FACTORS FOR MAXIMUM SAFE SPEEDS OF LS AND RIM WHEELS

Temperature °F.	Materials of construction					
	Mild steel	950X/ 960X*	Aluminum	304 SST	316 SST	347 SST
70	1.00	1.00	1.00	1.00	0.95	1.00
200	1.00	1.00	0.97	0.89	0.92	1.00
300	1.00	1.00	—	0.82	0.88	0.99
400	1.00	1.00	—	0.78	0.86	0.97
500	0.97	1.00	—	0.75	0.83	0.97
600	0.94	1.00	—	0.73	0.80	0.97
700	0.91	1.00	—	0.71	0.78	0.96
800	0.82	1.00	—	0.70	0.77	0.96
900	—	—	—	0.68	0.76	0.95
1000	—	—	—	—	0.75	0.94

Note: When more than one correction is made, the factors are combined by multiplying the factors.

CHART III TEMPERATURE CORRECTION FACTORS FOR MAXIMUM SAFE SPEEDS OF DH WHEELS

Temp. °F.	Materials of construction	
	Standard high-strength steel	Aluminum
70	1.00	1.00
200	1.00	0.97
300	1.00	—
400	1.00	—
500	0.99	—
600	0.95	—
700	0.91	—
800	0.87	—

CHART IV SP AND BHP CORRECTION FACTORS FOR TEMPERATURE [°F.]

Temp.	Factor
-50°	0.77
-25°	0.82
0°	0.87
20°	0.91
40°	0.94
60°	0.98
70°	1.00
80°	1.02
100°	1.06
120°	1.09
140°	1.13
160°	1.17
180°	1.21
200°	1.25
225°	1.29
250°	1.34
275°	1.39
300°	1.43
350°	1.53
375°	1.58
400°	1.62
450°	1.72
500°	1.81
550°	1.91
600°	2.00
700°	2.19
800°	2.38
900°	2.56
1000°	2.76

CHART V SP AND BHP CORRECTION FACTORS FOR ALTITUDE [ft. above sea level]

Altitude	Factor
0	1.00
500	1.02
1000	1.04
1500	1.06
2000	1.08
2500	1.10
3000	1.12
3500	1.14
4000	1.16
4500	1.18
5000	1.20
5500	1.22
6000	1.25
6500	1.27
7000	1.30
7500	1.32
8000	1.35
9000	1.40
10000	1.45

CHART VI SP AND BHP CORRECTION FACTORS FOR RAREFICATION [negative inlet pressure]

SP	Factor
5"	1.01
10"	1.03
15"	1.04
20"	1.05
25"	1.07
30"	1.08
35"	1.09
40"	1.11

USING CAPACITY TABLES

HOW TO USE CAPACITY TABLES

For a given fan size, wheel design, CFM, and static pressure, capacity tables are used to obtain outlet velocity, wheel RPM, and BHP. If capacities are at conditions other than 70°F., sea level, or standard density [.075 lbs./cu. ft.], correction factors must be applied to static pressure and BHP.

1. When conditions other than standard density [.075 lbs./cu. ft.] are involved, correct static pressure for air density. Refer to Charts IV, V, and VI.
2. Select size, wheel type, RPM, and BHP of fan from capacity table.
3. Check the maximum safe speed of the fan at operating temperature as shown in Charts I and II or III on page 6.
4. Determine actual performance at operating conditions by correcting static pressure and brake horsepower.

EXAMPLE

A fan is required for 9400 CFM, 24" SP, 5000 fpm outlet velocity at 300° F., sea level, and 20" negative inlet pressure, handling clean air.

1. Chart IV gives a 1.43 factor for 300°F. and Chart VI gives a 1.05 factor for rarefaction. Combined factor is 1.5[1.43 x 1.05]. Multiply 24" SP by 1.5 = 36" SP at standard density. Select from capacity tables for 9400 CFM at 36" SP.
2. A Size 334 Series 45 GI Fan with a DH wheel is selected for 9400 CFM, 36" SP, 4896 fpm outlet velocity at 2448 RPM and 78.3 BHP.
3. Chart I on page 6 indicates safe speed of the fan to be 2770 RPM and Chart III indicated a 1.0 factor for the standard steel wheel at 300°F. Fan is satisfactory to operate at 2448 RPM.
4. The performance at operating conditions would be 9400 CFM, 24" SP, 4896 fpm outlet velocity at 2448 RPM and 52.2 BHP [78.3 ÷ 1.5].

224 LS				Inlet diameter: 13" O.D. Outlet area: 0.91 sq. ft. inside								Wheel diameter: 22 5/8" Wheel circumference: 5.92 ft.											
CFM	OV	26"SP		28"SP		30"SP		32"SP		34"SP		35"SP		36"SP		37"SP		38"SP		39"SP		40"SP	
		RPM	BHP	RPM	BHP	RPM	BHP	RPM	BHP	RPM	BHP	RPM	BHP	RPM	BHP	RPM	BHP	RPM	BHP	RPM	BHP	RPM	BHP
2800	3077	3035	22.2	3145	24.2	3250	26.2	3350	28.3	3443	30.2	3498	31.4	3540	32.4	3599	33.7	3644	34.8	3690	35.9	3738	37.1
3200	3516	3050	24.4	3164	26.6	3266	28.7	3374	31.0	3466	33.1	3514	34.2	3563	35.4	3614	36.6	3666	37.9	3706	38.9	3747	40.0
3600	3956	3069	26.7	3187	29.2	3294	31.5	3390	33.7	3491	36.1	3533	37.2	3577	38.3	3632	39.7	3678	40.9	3713	41.9	3761	43.2
4000	4396	3106	29.6	3212	31.9	3308	34.1	3410	36.6	3509	39.2	3556	40.4	3604	41.7	3654	43.0	3694	44.2	3736	45.4	3789	46.9
4400	4835	3130	32.3	3238	34.8	3340	37.4	3432	39.8	3530	42.4	3581	43.8	3633	45.3	3669	46.3	3724	47.9	3761	49.1		
4800	5275	3156	35.1	3267	38.0	3373	40.8	3457	43.1	3561	46.0	3607	47.4	3655	48.8	3703	50.3	3753	51.9	3788	53.0		
5200	5714	3194	38.5	3297	41.2	3394	44.0	3497	47.0	3592	49.9	3635	51.2	3678	52.6	3723	54.0	3769	55.5				
5600	6154	3223	41.6	3328	44.7	3429	47.7	3525	50.7	3625	53.9	3664	55.2	3718	57.0	3759	58.4						
6000	6593	3263	45.3	3361	48.3	3465	51.6	3554	54.5	3658	58.1	3695	59.4	3744	61.2	3795	63.0						

264 LS				Inlet diameter: 15" O.D. Outlet area: 1.21 sq. ft. inside								Wheel diameter: 26 1/8" Wheel circumference: 6.84 ft.											
CFM	OV	26"SP		28"SP		30"SP		32"SP		34"SP		36"SP		38"SP		40"SP		42"SP		44"SP		46"SP	
		RPM	BHP	RPM	BHP	RPM	BHP	RPM	BHP	RPM	BHP	RPM	BHP	RPM	BHP	RPM	BHP	RPM	BHP	RPM	BHP	RPM	BHP
4500	3719	2647	33.8	2743	36.7	2837	39.8	2919	42.6	3016	46.0	3098	49.1	3174	52.1	3253	55.3	3324	58.3	3399	61.5	3477	65.0
5000	4132	2667	36.9	2768	40.2	2860	43.4	2942	46.4	3029	49.7	3111	52.9	3189	56.1	3270	59.5	3344	62.8	3422	66.4	3492	69.7
5500	4545	2688	40.3	2779	43.4	2877	47.0	2966	50.4	3044	53.5	3127	57.0	3215	60.8	3288	64.1	3365	67.7	3436	71.1	3509	74.7
6000	4959	2711	43.8	2806	47.3	2895	50.8	2976	54.0	3062	57.7	3153	61.6	3233	65.3	3300	68.5	3387	72.8	3461	76.5	3528	80.0
6500	5372	2745	47.9	2833	51.4	2915	54.8	3002	58.5	3095	62.6	3165	65.9	3252	70.1	3329	73.9	3394	77.2	3478	81.7	3548	85.5
7000	5785	2768	51.7	2861	55.6	2948	59.4	3029	63.1	3115	67.2	3192	71.0	3274	75.1	3345	78.8	3419	82.8	3496	87.2	3561	90.9
7500	6198	2802	56.2	2888	60.0	2970	63.8	3056	68.0	3136	72.0	3220	76.3	3296	80.4	3375	84.7	3444	88.7	3516	92.9	3591	97.4
8000	6612	2826	60.4	2917	64.7	3003	68.9	3084	73.0	3169	77.5	3237	81.2	3319	85.8	3393	90.1	3470	94.8	3538	98.9		
8500	7025	2860	65.2	2954	69.9	3026	73.7	3112	78.3	3192	82.7	3266	87.0	3355	92.2	3424	96.5	3497	101	3573	106		

294 LS				Inlet diameter: 17" O.D. Outlet area: 1.54 sq. ft. inside								Wheel diameter: 29 5/8" Wheel circumference: 7.76 ft.											
CFM	OV	26"SP		28"SP		30"SP		32"SP		34"SP		36"SP		38"SP		40"SP		42"SP		44"SP		46"SP	
		RPM	BHP	RPM	BHP	RPM	BHP	RPM	BHP	RPM	BHP	RPM	BHP	RPM	BHP	RPM	BHP	RPM	BHP	RPM	BHP	RPM	BHP
4800	3117	2322	36.7	2415	40.3	2494	43.6	2568	46.8	2646	50.4	2718	53.8	2793	57.5	2872	61.7	2942	65.5	3000	68.8	3076	73.3
5400	3506	2340	40.2	2422	43.6	2501	47.0	2585	50.9	2655	54.3	2728	57.9	2806	62.0	2876	65.9	2949	70.1	3014	73.9	3081	78.0
6000	3896	2343	43.3	2431	47.2	2510	50.8	2594	54.8	2665	58.4	2740	62.4	2820	66.8	2883	70.4	2948	74.3	3017	78.6	3089	83.2
6600	4286	2363	47.3	2443	51.0	2529	55.1	2605	59.0	2686	63.4	2754	67.2	2826	71.3	2902	75.9	2961	79.7	3034	84.4		
7200	4675	2382	51.4	2456	55.0	2534	59.0	2617	63.5	2691	67.6	2769	72.2	2834	76.2	2903	80.5	2976	85.3	3042	89.8		
7800	5065	2391	55.2	2470	59.3	2554	63.8	2631	68.2	2713	73.0	2785	77.5	2845	81.4	2924	86.6	2991	91.2	3061	96.2		
8400	5455	2412	59.7	2496	64.3	2574	68.9	2646	73.2	2721	77.9	2801	83.0	2871	87.8	2930	91.9	3007	97.4	3072	102		
9000	5844	2433	64.4	2511	69.0	2595	74.1	2662	78.3	2744	83.7	2806	87.9	2884	93.5	2952	98.5	3024	104	3084	109		
9600	6234	2453	69.2	2527	73.8	2606	78.8	2689	84.4	2755	89.0	2824	94.0	2897	99.4	2961	104	3028	110				

Performance certified is for installation Type D: Ducted inlet, Ducted outlet. Power rating (BHP) does not include transmission losses. Performance ratings do not include the effects of appurtenances (accessories).

334 LS				Inlet diameter: 19" O.D.					Wheel diameter: 33"														
				Outlet area: 1.92 sq. ft. inside					Wheel circumference: 8.64 ft.														
CFM	OV	26"SP		28"SP		30"SP		32"SP		34"SP		36"SP		38"SP		40"SP		42"SP		44"SP		46"SP	
		RPM	BHP	RPM	BHP	RPM	BHP	RPM	BHP	RPM	BHP	RPM	BHP	RPM	BHP	RPM	BHP	RPM	BHP	RPM	BHP	RPM	BHP
6000	3125	2086	43.8	2158	47.5	2228	51.2	2301	55.4	2370	59.5	2432	63.3	2498	67.6	2567	72.3	2627	76.6	2678	80.3	2744	85.3
6800	3542	2097	48.1	2168	52.0	2244	56.4	2309	60.3	2378	64.7	2442	68.9	2509	73.5	2569	77.8	2633	82.5	2700	87.7	2746	91.4
7600	3958	2109	52.8	2186	57.3	2254	61.5	2327	66.1	2388	70.2	2453	74.8	2522	79.7	2585	84.5	2642	89.0	2701	93.8	2763	99.0
8400	4375	2123	57.7	2204	62.8	2272	67.3	2344	72.2	2407	76.7	2474	81.6	2536	86.4	2601	91.6	2652	95.9	2715	101	2729	109
9200	4792	2147	63.6	2222	68.6	2290	73.3	2356	78.2	2426	83.5	2487	88.3	2551	93.5	2610	98.5	2672	104	2729	109	2753	118
10000	5208	2171	69.7	2240	74.6	2308	79.7	2381	85.3	2440	90.1	2501	95.2	2566	101	2628	106	2693	112	2753	118		
10800	5625	2194	76.0	2259	80.9	2327	86.3	2399	92.3	2465	97.9	2523	103	2583	109	2646	115	2706	120	2769	127		
11600	6042	2217	82.5	2286	88.1	2350	93.6	2418	99.5	2479	105	2544	111	2612	118	2671	124	2721	129				
12400	6458	2240	89.1	2305	94.8	2374	101	2447	108	2505	113	2565	120	2629	126	2684	132	2742	138				

364 LS				Inlet diameter: 21" O.D.					Wheel diameter: 36½"														
				Outlet area: 2.35 sq. ft. inside					Wheel circumference: 9.56 ft.														
CFM	OV	26"SP		28"SP		30"SP		32"SP		34"SP		36"SP		38"SP		40"SP		42"SP		44"SP		46"SP	
		RPM	BHP	RPM	BHP	RPM	BHP	RPM	BHP	RPM	BHP	RPM	BHP	RPM	BHP	RPM	BHP	RPM	BHP	RPM	BHP	RPM	BHP
7000	2979	1877	51.5	1947	56.1	2013	60.9	2075	65.5	2141	70.7	2200	75.6	2253	80.1	2319	86.1	2366	90.4	2426	96.3	2477	101
8000	3404	1889	56.9	1957	61.8	2022	66.8	2084	71.7	2150	77.2	2211	82.5	2266	87.6	2324	93.1	2374	98.1	2427	103	2482	109
9000	3830	1902	62.8	1969	67.9	2033	73.1	2102	79.0	2161	84.2	2222	90.0	2271	94.7	2331	101	2384	106	2441	112	2490	118
10000	4255	1916	68.9	1981	74.3	2051	80.4	2113	86.0	2172	91.6	2235	97.8	2286	103	2340	109	2404	116	2455	122		
11000	4681	1935	75.8	2005	82.0	2069	88.0	2125	93.5	2185	99.5	2248	106	2302	112	2358	118	2416	125	2462	131		
12000	5106	1953	83.0	2018	89.1	2086	96.0	2144	102	2204	108	2263	115	2318	121	2375	128	2429	135	2478	141		
13000	5532	1971	90.4	2040	97.4	2104	104	2162	111	2223	118	2277	124	2334	131	2393	138	2443	145	2495	152		
14000	5957	1997	98.9	2062	106	2121	113	2185	120	2242	127	2303	135	2356	142	2411	149	2457	156				
15000	6383	2022	108	2083	115	2147	123	2207	130	2261	137	2318	145	2377	153	2429	160	2484	168				

404 RIM				Inlet diameter: 23" O.D.					Wheel diameter: 40"														
				Outlet area: 2.86 sq. ft. inside					Wheel circumference: 10.47 ft.														
CFM	OV	26"SP		28"SP		30"SP		32"SP		34"SP		36"SP		38"SP		40"SP		42"SP		44"SP		46"SP	
		RPM	BHP	RPM	BHP	RPM	BHP	RPM	BHP	RPM	BHP	RPM	BHP	RPM	BHP	RPM	BHP	RPM	BHP	RPM	BHP	RPM	BHP
11000	3793	1709	71.7	1770	77.5	1829	83.5	1886	89.5	1946	96.2	1996	102	2048	108	2103	115	2153	121	2205	128	2250	135
12200	4207	1721	78.8	1781	85.0	1840	91.4	1897	97.9	1951	104	2002	111	2056	117	2112	125	2157	131	2203	138	2252	145
13400	4621	1737	86.6	1792	92.8	1851	99.6	1908	107	1963	114	2016	120	2064	127	2116	134	2170	142	2212	149	2264	157
14600	5034	1753	94.7	1813	102	1867	109	1925	116	1976	123	2029	131	2080	138	2133	146	2183	154	2222	160	2276	169
15800	5448	1769	103	1824	110	1883	118	1937	125	1993	134	2043	141	2095	149	2139	156	2191	165	2239	173	2282	180
17000	5862	1784	111	1844	120	1899	128	1957	136	2010	145	2057	152	2106	160	2157	169	2205	177	2255	186		
18200	6276	1806	121	1862	129	1922	139	1969	146	2027	156	2071	163	2126	173	2174	181	2224	191	2266	199		
19400	6690	1828	131	1888	140	1937	149	1989	157	2044	167	2094	176	2146	186	2191	194	2239	204				
20600	7103	1848	141	1905	151	1959	160	2009	169	2061	179	2116	189	2157	197	2208	208	2253	217				

454 RIM				Inlet diameter: 26" O.D.					Wheel diameter: 45½"														
				Outlet area: 3.64 sq. ft. inside					Wheel circumference: 11.81 ft.														
CFM	OV	26"SP		28"SP		30"SP		32"SP		34"SP		36"SP		38"SP		40"SP		42"SP		44"SP		46"SP	
		RPM	BHP	RPM	BHP	RPM	BHP	RPM	BHP	RPM	BHP	RPM	BHP	RPM	BHP	RPM	BHP	RPM	BHP	RPM	BHP	RPM	BHP
13800	3791	1501	88.0	1557	95.3	1611	103	1663	110	1713	118	1759	125	1807	133	1851	140	1896	148	1945	157	1986	164
15200	4176	1506	96.1	1562	104	1616	112	1663	119	1719	128	1767	136	1811	144	1857	152	1898	159	1941	168	1987	177
16600	4560	1521	106	1572	113	1626	122	1675	130	1721	138	1770	147	1815	155	1864	164	1901	172	1947	181	1996	191
18000	4945	1527	114	1582	123	1632	132	1681	141	1734	150	1774	158	1826	168	1871	177	1912	185	1954	195	1992	203
19400	5330	1540	125	1592	133	1639	142	1689	151	1741	162	1788	171	1827	179	1879	190	1922	200	1962	209		
20800	5714	1554	135	1602	144	1653	154	1700	163	1750	173	1793	183	1839	193	1887	204	1927	213	1969	223		
22200	6099	1566	145	1619	156	1667	166	1712	175	1758	186	1807	197	1850	207	1896	218	1933	227	1983	239		
23600	6484	1579	156	1628	167	1681	178	1723	188	1774	200	1821	211	1862	221	1904	232	1949	244	1986	254		
25000	6868	1597	169	1644	179	1694	191	1741	202	1783	212	1827	224	1873	236	1914	247	1956	258	2000	271		

504 RIM				Inlet diameter: 29" O.D.					Wheel diameter: 50½"														
				Outlet area: 4.57 sq. ft. inside					Wheel circumference: 13.22 ft.														
CFM	OV	26"SP		28"SP		30"SP		32"SP		34"SP		36"SP		38"SP		40"SP		42"SP		44"SP		46"SP	
		RPM	BHP	RPM	BHP	RPM	BHP	RPM	BHP	RPM	BHP	RPM	BHP	RPM	BHP	RPM	BHP	RPM	BHP	RPM	BHP	RPM	BHP
16000	3501	1341	103	1390	112	1433	120	1483	130	1525	138	1570	147	1610	156	1653	165	1697	176	1737	185	1769	193
18000	3939	1345	115	1394	124	1441	133	1486	143	1529	152	1574	162	1615	172	1659	182	1699	192	1734	201	1777	213
20000	4376	1351	126	1398	136	1449	147	1495	157	1533	166	1579	177	1622	188	1661	198	1702	209	1740	220	1779	231
22000	4814	1364	140	1408	150	1454	161	1504	173	1543	183	1584	193	1623	204	1664	215	1707	227	1746	239	1782	250
24000	5252	1373	154	1420	165	1467	176	1512	188	1553	199	1595	211	1631	221	1678	235	1718	248	1749	257	1792	271
26000	5689	1389	169	1432	180	1479	193	1521	205	1563	217	1606	230	1648	242	1682	253	1719	265	1757	278	1796	292
28000	6127	1400	183	1447	197	1491	209	1530	221	1572	234	1617	248	1655	261	1696	275	1730	287	1765	299	1802	313
30000	6565	1411	199	1461	214	1502	226	1546	240	1586	254	1627	268	1663	280	1701	294	1741	309	1783	325		
32000	7002	1428	215	1475	231	1520	246	1561	260	1598	273	1638	288	1679	303	1715	317	1752	331	1791	347		

Performance certified is for installation Type D: Ducted inlet, Ducted outlet. Power rating (BHP) does not include transmission losses. Performance ratings do not include the effects of appurtenances (accessories).

574 RIM				Inlet diameter: 33" O.D. Outlet area: 5.93 sq. ft. inside					Wheel diameter: 57½" Wheel circumference: 15.05 ft.														
CFM	OV	26"SP		28"SP		30"SP		32"SP		34"SP		36"SP		38"SP		40"SP		42"SP		44"SP		46"SP	
		RPM	BHP	RPM	BHP	RPM	BHP	RPM	BHP	RPM	BHP	RPM	BHP	RPM	BHP	RPM	BHP	RPM	BHP	RPM	BHP	RPM	BHP
21000	3541	1177	135	1221	147	1262	158	1302	169	1339	180	1378	192	1419	206	1451	216	1490	230	1524	242	1560	255
23500	3963	1179	149	1226	162	1267	174	1303	185	1345	199	1380	210	1422	225	1455	237	1490	250	1527	264	1559	276
26000	4384	1189	165	1231	178	1269	190	1309	203	1351	218	1387	231	1426	245	1456	256	1498	273	1531	286	1565	301
28500	4806	1198	182	1237	194	1278	209	1315	222	1354	236	1395	252	1430	266	1466	281	1500	295	1535	310	1567	324
31000	5228	1207	199	1249	213	1287	228	1328	243	1364	258	1402	273	1434	287	1468	302	1503	317	1540	335	1569	348
33500	5649	1215	216	1254	231	1296	247	1334	263	1374	280	1410	296	1443	311	1479	327	1511	343	1546	360	1577	376
36000	6071	1228	236	1265	251	1304	267	1346	286	1384	303	1417	318	1452	335	1489	354	1519	369	1551	386	1585	404
38500	6492	1241	256	1281	273	1318	290	1358	309	1394	326	1425	342	1464	362	1499	380	1528	396	1561	415		
41000	6914	1253	276	1291	294	1332	314	1369	332	1403	350	1438	369	1469	386	1508	408	1536	423	1571	444		

644 RIM				Inlet diameter: 37" O.D. Outlet area: 7.48 sq. ft. inside					Wheel diameter: 64¾" Wheel circumference: 16.85 ft.														
CFM	OV	26"SP		28"SP		30"SP		32"SP		34"SP		36"SP		38"SP		40"SP		42"SP		44"SP		46"SP	
		RPM	BHP	RPM	BHP	RPM	BHP	RPM	BHP	RPM	BHP	RPM	BHP	RPM	BHP	RPM	BHP	RPM	BHP	RPM	BHP	RPM	BHP
26000	3476	1050	167	1089	182	1128	196	1164	211	1198	225	1233	240	1266	255	1300	271	1330	285	1361	301	1388	314
29500	3944	1054	187	1096	204	1129	218	1165	233	1199	248	1235	265	1268	281	1298	296	1330	313	1363	330	1392	346
33000	4412	1061	209	1099	225	1136	242	1172	258	1206	275	1238	291	1272	309	1303	326	1336	345	1365	362	1396	380
36500	4880	1071	232	1108	250	1145	268	1178	285	1212	303	1245	321	1280	341	1308	357	1338	375	1369	394	1401	415
40000	5348	1080	257	1117	276	1151	294	1187	313	1219	331	1252	351	1284	371	1318	392	1349	412	1373	428	1407	451
43500	5816	1091	283	1126	302	1163	323	1196	343	1231	365	1263	384	1295	406	1323	425	1352	444	1382	466	1413	489
47000	6283	1102	309	1139	331	1173	353	1205	373	1238	395	1272	418	1303	440	1335	463	1362	483	1390	504	1419	527
50500	6751	1116	339	1151	361	1184	383	1218	407	1249	429	1282	453	1311	475	1341	498	1372	523	1398	544		
54000	7219	1130	369	1163	392	1198	417	1231	442	1260	464	1291	488	1324	515	1352	538	1382	563	1412	590		

714 RIM				Inlet diameter: 41" O.D. Outlet area: 9.17 sq. ft. inside					Wheel diameter: 71¼" Wheel circumference: 18.65 ft.														
CFM	OV	26"SP		28"SP		30"SP		32"SP		34"SP		36"SP		38"SP		40"SP		42"SP		44"SP		46"SP	
		RPM	BHP	RPM	BHP	RPM	BHP	RPM	BHP	RPM	BHP	RPM	BHP	RPM	BHP	RPM	BHP	RPM	BHP	RPM	BHP	RPM	BHP
32000	3490	951	207	983	223	1017	240	1050	258	1085	278	1112	294	1141	311	1172	331	1199	348	1227	367	1256	388
36000	3926	952	228	990	249	1021	266	1053	285	1084	304	1117	324	1143	341	1174	363	1203	383	1228	401	1259	425
40000	4362	959	254	994	274	1025	293	1057	313	1089	334	1122	356	1149	376	1178	396	1203	416	1235	440	1258	459
44000	4798	966	280	998	300	1032	322	1061	342	1093	365	1123	387	1155	411	1181	431	1209	453	1237	477	1263	499
48000	5234	973	306	1007	330	1038	352	1071	376	1101	398	1132	423	1158	444	1185	467	1214	492	1244	518	1267	540
52000	5671	984	337	1015	360	1047	384	1078	409	1108	433	1137	458	1167	484	1193	507	1219	531	1247	557	1276	586
56000	6107	993	368	1023	391	1055	417	1084	442	1115	469	1147	498	1176	525	1200	547	1228	575	1257	604		
60000	6543	1003	399	1035	427	1066	453	1098	482	1127	510	1152	534	1184	566	1207	589	1236	619	1260	646		
64000	6979	1015	434	1046	462	1075	489	1106	519	1133	546	1162	576	1192	608	1219	637	1247	668	1270	694		

784 RIM				Inlet diameter: 45" O.D. Outlet area: 11.06 sq. ft. inside					Wheel diameter: 78¼" Wheel circumference: 20.49 ft.														
CFM	OV	26"SP		28"SP		30"SP		32"SP		34"SP		36"SP		38"SP		40"SP		42"SP		44"SP		46"SP	
		RPM	BHP	RPM	BHP	RPM	BHP	RPM	BHP	RPM	BHP	RPM	BHP	RPM	BHP	RPM	BHP	RPM	BHP	RPM	BHP	RPM	BHP
45000	4069	870	286	901	309	931	332	960	355	988	377	1017	402	1043	426	1072	452	1097	476	1119	498	1147	526
49500	4476	874	314	905	338	936	363	965	388	993	413	1019	437	1047	463	1073	489	1100	516	1124	541	1149	569
54000	4882	881	343	912	370	940	394	969	422	995	446	1026	476	1051	502	1078	530	1103	557	1129	586	1152	613
58500	5289	887	374	918	402	946	429	976	459	1003	486	1031	516	1055	541	1080	569	1106	599	1134	632	1155	658
63000	5696	896	409	926	437	952	464	981	494	1011	526	1037	556	1062	585	1088	616	1113	646	1138	679	1158	705
67500	6103	905	444	933	473	962	505	989	535	1018	568	1042	598	1069	630	1093	661	1119	695	1143	727	1168	761
72000	6510	914	480	940	509	968	541	997	577	1024	610	1048	640	1077	678	1098	706	1125	744	1148	776		
76500	6917	922	516	950	550	977	583	1005	619	1031	652	1057	689	1081	721	1105	756	1131	793	1158	834		
81000	7324	933	556	960	592	989	630	1017	667	1041	701	1067	738	1089	771	1117	814	1142	852	1162	884		

854 RIM				Inlet diameter: 49" O.D. Outlet area: 13.13 sq. ft. inside					Wheel diameter: 85¼" Wheel circumference: 22.32 ft.														
CFM	OV	26"SP		28"SP		30"SP		32"SP		34"SP		36"SP		38"SP		40"SP		42"SP		44"SP		46"SP	
		RPM	BHP	RPM	BHP	RPM	BHP	RPM	BHP	RPM	BHP	RPM	BHP	RPM	BHP	RPM	BHP	RPM	BHP	RPM	BHP	RPM	BHP
50000	3808	801	325	830	352	859	381	887	410	914	438	938	465	964	495	987	523	1012	553	1033	581	1055	610
55000	4189	807	356	835	383	861	411	889	441	916	472	942	502	965	531	990	563	1012	592	1035	623	1059	657
60000	4570	813	387	841	417	868	447	894	477	919	507	945	541	970	573	992	603	1016	636	1041	672	1063	706
65000	4950	821	421	847	451	874	484	899	514	924	547	951	583	974	615	998	649	1020	682	1043	717	1064	749
70000	5331	828	456	854	488	882	524	905	554	932	590	955	623	981	662	1004	696	1028	733	1049	768		
75000	5712	835	491	861	526	888	561	911	595	939	634	963	671	988	710	1009	744	1031					

224 DH				Inlet diameter: 13" O.D.					Wheel diameter: 22½"														
				Outlet area: 0.91 sq. ft. inside					Wheel circumference: 5.92 ft.														
CFM	OV	26"SP		28"SP		30"SP		32"SP		34"SP		35"SP		36"SP		37"SP		38"SP		39"SP		40"SP	
		RPM	BHP	RPM	BHP	RPM	BHP	RPM	BHP	RPM	BHP	RPM	BHP	RPM	BHP	RPM	BHP	RPM	BHP	RPM	BHP	RPM	BHP
2800	3077	3011	18.4	3127	20.1	3221	21.5	3337	23.4	3426	24.9	3481	25.9	3528	26.7	3577	27.6	3617	28.4	3668	29.3	3721	30.3
3200	3516	3025	20.3	3139	22.1	3247	24.0	3349	25.8	3441	27.4	3489	28.3	3538	29.3	3589	30.3	3641	31.3	3677	32.1	3732	33.2
3600	3956	3052	22.5	3165	24.5	3261	26.2	3363	28.2	3458	30.0	3515	31.2	3559	32.1	3604	33.1	3650	34.1	3697	35.1	3745	36.2
4000	4396	3079	24.8	3180	26.7	3288	28.8	3392	30.9	3490	33.0	3528	33.8	3580	35.0	3620	35.9	3675	37.2	3717	38.2	3761	39.2
4400	4835	3105	27.1	3216	29.3	3315	31.4	3409	33.4	3498	35.7	3554	36.8	3602	37.9	3650	39.1	3688	40.0	3739	41.3	3778	42.3
4800	5275	3140	29.6	3242	31.8	3350	34.3	3447	36.5	3528	38.5	3581	39.8	3635	41.2	3679	42.4	3725	43.6	3760	44.5		
5200	5714	3173	32.2	3284	34.7	3385	37.2	3474	39.4	3568	41.9	3607	42.9	3657	44.3	3708	45.7	3750	46.9				
5600	6154	3220	35.1	3324	37.7	3418	40.2	3509	42.6	3605	45.3	3642	46.4	3698	48.0	3736	49.1	3775	50.3				
6000	6593	3264	38.2	3362	40.8	3450	43.2	3543	45.9	3642	48.8	3684	50.1	3728	51.5								

264 DH				Inlet diameter: 15" O.D.					Wheel diameter: 26½"														
				Outlet area: 1.21 sq. ft. inside					Wheel circumference: 6.84 ft.														
CFM	OV	26"SP		28"SP		30"SP		32"SP		34"SP		36"SP		38"SP		40"SP		42"SP		44"SP		46"SP	
		RPM	BHP	RPM	BHP	RPM	BHP	RPM	BHP	RPM	BHP	RPM	BHP	RPM	BHP	RPM	BHP	RPM	BHP	RPM	BHP	RPM	BHP
4500	3719	2629	28.3	2724	30.8	2815	33.2	2900	35.6	2990	38.2	3072	40.7	3159	43.4	3235	45.9	3314	48.6	3381	50.9	3459	53.8
5000	4132	2647	31.0	2743	33.6	2835	36.3	2922	38.9	3004	41.5	3089	44.3	3167	46.9	3248	49.7	3319	52.3	3394	55.1	3471	58.1
5500	4545	2674	34.0	2770	36.8	2854	39.4	2944	42.3	3029	45.2	3107	47.9	3189	50.9	3263	53.6	3340	56.6	3408	59.3	3478	62.2
6000	4959	2699	37.0	2788	39.8	2874	42.7	2956	45.5	3043	48.6	3125	51.6	3200	54.5	3278	57.6	3361	61.0	3435	64.2	3500	67.0
6500	5372	2732	40.3	2814	43.1	2902	46.2	2987	49.3	3067	52.4	3152	55.8	3222	58.6	3295	61.7	3382	65.5	3450	68.5	3521	71.8
7000	5785	2755	43.5	2847	46.8	2929	49.9	3016	53.3	3091	56.3	3170	59.6	3244	62.8	3321	66.3	3402	70.0	3466	73.0	3543	76.8
7500	6198	2792	47.1	2871	50.2	2955	53.6	3044	57.3	3123	60.7	3206	64.3	3275	67.5	3347	71.0	3423	74.6	3492	78.1	3564	81.8
8000	6612	2820	50.7	2908	54.3	2988	57.6	3072	61.3	3146	64.7	3223	68.3	3305	72.3	3373	75.7	3444	79.3	3518	83.3	3595	87.4
8500	7025	2860	54.7	2944	58.4	3032	62.4	3113	66.1	3183	69.5	3256	73.2	3333	77.1	3414	81.4	3481	85.1	3552	89.0		

294 DH				Inlet diameter: 17" O.D.					Wheel diameter: 29½"														
				Outlet area: 1.54 sq. ft. inside					Wheel circumference: 7.76 ft.														
CFM	OV	26"SP		28"SP		30"SP		32"SP		34"SP		36"SP		38"SP		40"SP		42"SP		44"SP		46"SP	
		RPM	BHP	RPM	BHP	RPM	BHP	RPM	BHP	RPM	BHP	RPM	BHP	RPM	BHP	RPM	BHP	RPM	BHP	RPM	BHP	RPM	BHP
5600	3636	2300	35.0	2380	38.0	2455	40.9	2535	44.2	2608	47.3	2685	50.8	2753	54.0	2825	57.4	2884	60.5	2955	64.1	3020	67.7
6200	4026	2310	37.7	2392	40.9	2469	44.1	2552	47.7	2618	50.7	2699	54.6	2761	57.6	2838	61.6	2906	65.2	2962	68.3	3036	72.6
6800	4416	2329	40.7	2412	44.2	2493	47.8	2569	51.3	2639	54.7	2714	58.5	2781	62.0	2851	65.8	2913	69.3	2977	73.0	3045	77.1
7400	4805	2348	43.9	2432	47.7	2506	51.1	2576	54.5	2650	58.3	2728	62.4	2790	65.8	2865	70.1	2922	73.5	2993	77.8	3054	81.7
8000	5195	2372	47.4	2452	51.1	2528	54.9	2602	58.7	2670	62.4	2743	66.5	2809	70.3	2880	74.5	2942	78.5	3008	82.7	3077	87.2
8600	5584	2396	50.9	2477	55.0	2549	58.8	2626	62.9	2690	66.6	2766	71.1	2829	74.9	2903	79.6	2962	83.5	3023	87.6	3087	92.0
9200	5974	2425	54.9	2502	58.9	2577	63.1	2649	67.2	2717	71.3	2789	75.8	2856	80.1	2917	84.2	2982	88.6	3039	92.6		
9800	6364	2453	58.9	2525	62.9	2603	67.5	2671	71.6	2743	76.1	2811	80.6	2874	84.8	2940	89.4	3001	93.8	3064	98.4		
10400	6753	2485	63.3	2554	67.4	2628	71.9	2699	76.5	2767	81.0	2832	85.4	2899	90.2	2970	95.3	3028	99.7	3088	104		

334 DH				Inlet diameter: 19" O.D.					Wheel diameter: 33"														
				Outlet area: 1.92 sq. ft. inside					Wheel circumference: 8.64 ft.														
CFM	OV	26"SP		28"SP		30"SP		32"SP		34"SP		36"SP		38"SP		40"SP		42"SP		44"SP		46"SP	
		RPM	BHP	RPM	BHP	RPM	BHP	RPM	BHP	RPM	BHP	RPM	BHP	RPM	BHP	RPM	BHP	RPM	BHP	RPM	BHP	RPM	BHP
7000	3646	2061	43.2	2131	46.7	2205	50.6	2275	54.5	2338	58.2	2404	62.2	2463	65.9	2525	70.0	2589	74.3	2643	78.2	2700	82.3
7800	4063	2077	47.2	2148	51.0	2215	54.8	2286	59.1	2352	63.2	2422	67.7	2486	72.0	2541	75.9	2599	80.1	2660	84.6	2711	88.6
8600	4479	2100	51.6	2172	55.8	2233	59.6	2306	64.2	2366	68.3	2430	72.6	2497	77.4	2558	81.9	2610	86.0	2677	91.3	2734	96.0
9400	4896	2114	55.7	2187	60.3	2250	64.4	2325	69.5	2389	74.0	2448	78.3	2509	83.0	2574	88.1	2632	92.8	2682	97.1	2746	103
10200	5313	2141	60.7	2209	65.2	2274	69.8	2337	74.3	2410	79.9	2473	84.7	2530	89.3	2590	94.4	2643	99.0	2699	104	2758	109
11000	5729	2166	65.7	2235	70.7	2297	75.3	2362	80.3	2431	85.8	2489	90.6	2550	95.8	2606	101	2664	106	2716	111		
11800	6146	2189	70.8	2255	75.8	2325	81.3	2386	86.3	2451	91.8	2505	96.5	2569	102	2629	108	2684	113	2741	119		
12600	6563	2212	76.0	2285	81.8	2351	87.4	2409	92.4	2470	97.9	2534	104	2588	109	2652	115	2703	120	2765	127		
13400	6979	2244	82.1	2313	88.0	2376	93.5	2437	99.1	2501	105	2562	111	2614	116	2674	123	2737	129				

364 DH				Inlet diameter: 21" O.D.					Wheel diameter: 36½"														
				Outlet area: 2.35 sq. ft. inside					Wheel circumference: 9.56 ft.														
CFM	OV	26"SP		28"SP		30"SP		32"SP		34"SP		36"SP		38"SP		40"SP		42"SP		44"SP		46"SP	
		RPM	BHP	RPM	BHP	RPM	BHP	RPM	BHP	RPM	BHP	RPM	BHP	RPM	BHP	RPM	BHP	RPM	BHP	RPM	BHP	RPM	BHP
8000	3404	1856	50.1	1923	54.5	1986	58.9	2054	63.8	2105	67.6	2169	72.7	2226	77.4	2286	82.5	2336	87.0	2389	91.8	2444	97.1
9000	3830	1873	55.2	1933	59.4	1997	64.2	2057	68.8	2120	73.9	2177	78.8	2238	84.1	2291	89.0	2347	94.3	2394	98.8	2455	105
10000	4255	1888	60.3	1950	65.0	2015	70.2	2077	75.4	2135	80.4	2195	85.9	2250	91.0	2308	96.6	2358	102	2411	107	2466	113
11000	4681	1903	65.5	1966	70.6	2026	75.7	2089	81.3	2149	86.9	2205	92.2	2263	98.0	2315	103	2370	109	2418	115	2478	121
12000	5106	1924	71.3	1987	76.8	2049	82.5	2108	88.1	2171	94.3	2222	99.5	2275	105	2332	111	2382	117	2435	123	2490	130
13000	5532	1948	77.6	2008	83.2	2071	89.3	2126	94.9	2184	101	2238	107	2295	113	2348	119	2402	126	2451	132		
14000	5957	1966	83.5	2027	89.6	2092	96.3	2149	102	2204	109	2261	115	2314	122	2371	128	2422	135	2475	142		
15000	6383	1993	90.5	2051	96.6	2112	103	2166	109	2223	116	2283	123	2333	130	2386	137	2441	144	2491	151		
16000	6809	2018	97.5	2078	104	2136	111	2193	118	2247	125	2304											

404 DH				Inlet diameter: 23" O.D.					Wheel diameter: 40"														
				Outlet area: 2.86 sq. ft. inside					Wheel circumference: 10.47 ft.														
CFM	OV	26"SP		28"SP		30"SP		32"SP		34"SP		36"SP		38"SP		40"SP		42"SP		44"SP		46"SP	
		RPM	BHP	RPM	BHP	RPM	BHP	RPM	BHP	RPM	BHP	RPM	BHP	RPM	BHP	RPM	BHP	RPM	BHP	RPM	BHP	RPM	BHP
11000	3846	1669	65.5	1732	71.3	1785	76.4	1840	82.1	1890	87.4	1944	93.2	1990	98.5	2039	104	2091	111	2140	117	2191	123
12200	4266	1688	72.2	1745	77.9	1799	83.6	1857	90.0	1903	95.2	1959	102	2010	108	2055	114	2102	120	2151	126	2191	132
13400	4685	1704	78.9	1757	84.6	1813	90.9	1866	97.1	1922	104	1974	111	2021	117	2070	123	2112	129	2166	137	2203	143
14600	5105	1720	85.6	1780	92.6	1832	98.9	1888	106	1940	113	1988	119	2038	126	2084	133	2131	140	2181	148	2224	154
15800	5524	1740	93.0	1801	101	1850	107	1902	114	1951	121	2002	128	2055	136	2097	143	2149	151	2187	157	2235	165
17000	5944	1763	101	1821	109	1873	116	1927	124	1973	131	2021	138	2071	146	2117	153	2166	162	2209	169	2254	177
18200	6364	1785	109	1840	117	1894	125	1945	133	1994	140	2039	148	2087	156	2136	164	2182	173	2229	181	2272	189
19400	6783	1814	119	1867	127	1913	134	1967	143	2014	150	2068	160	2113	168	2161	177	2204	185	2249	194		
20600	7203	1833	127	1892	136	1942	145	1993	154	2043	162	2084	170	2138	180	2183	189	2225	197	2268	206		

454 DH				Inlet diameter: 26" O.D.					Wheel diameter: 45 1/8"														
				Outlet area: 3.64 sq. ft. inside					Wheel circumference: 11.81 ft.														
CFM	OV	26"SP		28"SP		30"SP		32"SP		34"SP		36"SP		38"SP		40"SP		42"SP		44"SP		46"SP	
		RPM	BHP	RPM	BHP	RPM	BHP	RPM	BHP	RPM	BHP	RPM	BHP	RPM	BHP	RPM	BHP	RPM	BHP	RPM	BHP	RPM	BHP
14500	3984	1485	86.0	1539	93.4	1583	99.9	1631	107	1681	115	1727	122	1775	130	1818	138	1858	145	1899	153	1938	160
16000	4396	1497	93.9	1552	102	1599	109	1649	117	1695	125	1737	132	1781	140	1827	149	1867	156	1909	165	1953	174
17500	4808	1513	103	1564	111	1613	119	1659	127	1708	135	1753	144	1793	152	1836	160	1880	169	1919	177	1959	186
19000	5220	1529	111	1581	120	1626	128	1674	137	1720	146	1761	154	1812	164	1851	173	1893	182	1936	191	1973	200
20500	5632	1551	122	1596	130	1644	139	1694	149	1737	157	1782	167	1823	176	1866	185	1904	194	1945	204	1987	214
22000	6044	1569	131	1615	140	1665	150	1708	159	1753	169	1800	180	1839	189	1880	198	1922	209	1960	218	2000	228
23500	6456	1589	142	1637	152	1685	162	1730	172	1773	182	1818	193	1860	203	1899	213	1939	223	1975	233		
25000	6868	1611	153	1658	163	1703	174	1751	185	1792	195	1835	206	1875	216	1917	227	1955	238	1995	249		
26500	7280	1633	165	1681	176	1725	186	1771	198	1814	209	1851	219	1899	232	1939	243	1976	254				

504 DH				Inlet diameter: 29" O.D.					Wheel diameter: 50 1/2"														
				Outlet area: 4.57 sq. ft. inside					Wheel circumference: 13.22 ft.														
CFM	OV	26"SP		28"SP		30"SP		32"SP		34"SP		36"SP		38"SP		40"SP		42"SP		44"SP		46"SP	
		RPM	BHP	RPM	BHP	RPM	BHP	RPM	BHP	RPM	BHP	RPM	BHP	RPM	BHP	RPM	BHP	RPM	BHP	RPM	BHP	RPM	BHP
18000	3939	1325	107	1373	116	1414	124	1457	133	1502	143	1544	152	1580	161	1618	170	1658	180	1699	190	1734	200
19800	4333	1339	117	1384	126	1426	135	1471	145	1513	155	1551	164	1591	174	1633	185	1669	195	1708	205	1740	214
21600	4726	1352	127	1398	137	1438	146	1480	156	1524	167	1565	178	1601	188	1640	198	1680	210	1716	220	1752	231
23400	5120	1364	137	1407	148	1453	159	1492	169	1534	180	1577	191	1611	201	1653	213	1684	223	1724	235	1758	246
25200	5514	1380	149	1424	160	1468	171	1509	182	1548	193	1589	205	1626	216	1660	227	1701	240	1738	252	1770	263
27000	5908	1394	160	1440	172	1481	184	1525	196	1561	207	1600	219	1640	232	1677	244	1716	257	1751	269	1787	282
28800	6302	1414	173	1455	185	1498	197	1539	210	1579	222	1615	234	1654	247	1694	261	1725	273	1764	287	1798	299
30600	6696	1433	187	1476	200	1514	211	1553	224	1595	238	1630	250	1671	265	1704	277	1744	292	1776	304	1808	317
32400	7090	1448	199	1493	213	1532	226	1570	239	1610	253	1652	269	1687	282	1724	296	1757	309	1792	323		

574 DH				Inlet diameter: 33" O.D.					Wheel diameter: 57 1/2"														
				Outlet area: 5.93 sq. ft. inside					Wheel circumference: 15.05 ft.														
CFM	OV	26"SP		28"SP		30"SP		32"SP		34"SP		36"SP		38"SP		40"SP		42"SP		44"SP		46"SP	
		RPM	BHP	RPM	BHP	RPM	BHP	RPM	BHP	RPM	BHP	RPM	BHP	RPM	BHP	RPM	BHP	RPM	BHP	RPM	BHP	RPM	BHP
24000	4047	1169	143	1206	153	1246	165	1284	177	1323	190	1359	202	1390	213	1423	225	1458	238	1494	252	1525	264
26500	4469	1180	156	1219	168	1256	180	1295	193	1331	206	1369	220	1404	233	1434	245	1465	257	1498	271	1533	286
29000	4890	1190	170	1230	183	1269	197	1305	210	1343	224	1378	238	1410	251	1443	265	1478	280	1509	293	1540	307
31500	5312	1203	185	1245	200	1280	213	1318	228	1354	242	1387	256	1421	271	1458	287	1490	302	1518	315	1548	329
34000	5734	1219	201	1258	216	1295	231	1331	246	1365	260	1400	276	1437	293	1466	306	1501	324	1528	337	1561	354
36500	6155	1237	219	1274	234	1309	249	1347	266	1378	280	1416	298	1446	313	1483	331	1512	346	1542	362	1573	379
39000	6577	1253	236	1292	253	1326	269	1361	286	1395	302	1431	320	1464	337	1495	353	1526	371	1555	387	1584	403
41500	6998	1271	256	1308	273	1341	289	1379	307	1411	324	1445	342	1477	359	1510	378	1540	396	1572	414		
44000	7420	1288	275	1324	293	1362	312	1395	329	1429	348	1462	367	1496	386	1524	403	1553	421	1588	442		

644 DH				Inlet diameter: 37" O.D.					Wheel diameter: 64 3/8"														
				Outlet area: 7.48 sq. ft. inside					Wheel circumference: 16.85 ft.														
CFM	OV	26"SP		28"SP		30"SP		32"SP		34"SP		36"SP		38"SP		40"SP		42"SP		44"SP		46"SP	
		RPM	BHP	RPM	BHP	RPM	BHP	RPM	BHP	RPM	BHP	RPM	BHP	RPM	BHP	RPM	BHP	RPM	BHP	RPM	BHP	RPM	BHP
32000	4278	1049	189	1085	204	1119	219	1150	233	1184	249	1219	267	1246	281	1280	299	1309	315	1340	332	1366	348
35000	4679	1060	206	1093	221	1128	238	1162	254	1193	270	1226	287	1255	304	1286	321	1313	337	1347	358	1371	372
38000	5080	1069	223	1104	240	1141	258	1172	275	1206	293	1236	311	1264	327	1297	347	1323	363	1354	383	1381	401
41000	5481	1082	241	1118	260	1149	277	1182	296	1217	316	1246	334	1276	352	1303	370	1331	388	1361	408	1391	430
44000	5882	1096	262	1130	281	1163	300	1195	319	1228	339	1259	359	1287	378	1317	398	1344	417	1372	437	1401	459
47000	6283	1109	282	1145	303	1177	323	1210	344	1238	362	1267	382	1298	404	1326	424	1356	446	1382	466	1409	487
50000	6684	1124	305	1159	326	1189	346	1221	367	1254	390	1282	411	1312	432	1339	453	1367	475	1396	498		
53000	7086	1139	327	1172	349	1206	373	1237	395	1266	416	1296	439	1325	461	1354	485	1381	507	1409	531		
56000	7487	1157	353	1189	376	1217	396	1250	420	1281	444	1310	468	1337	490	1365	514	1395	540	1418	560		

Performance certified is for installation Type D: Ducted inlet, Ducted outlet. Power rating (BHP) does not include transmission losses. Performance ratings do not include the effects of appurtenances (accessories).

714 DH				Inlet diameter: 41" O.D.				Wheel diameter: 71¼"															
				Outlet area: 9.17 sq. ft. inside				Wheel circumference: 18.65 ft.															
CFM	OV	26"SP		28"SP		30"SP		32"SP		34"SP		36"SP		38"SP		40"SP		42"SP		44"SP		46"SP	
		RPM	BHP	RPM	BHP	RPM	BHP	RPM	BHP	RPM	BHP	RPM	BHP	RPM	BHP	RPM	BHP	RPM	BHP	RPM	BHP	RPM	BHP
38000	4144	945	225	975	241	1006	260	1040	280	1067	297	1095	316	1125	336	1151	354	1178	374	1206	396	1230	414
41500	4526	953	244	984	262	1017	283	1044	301	1077	323	1103	341	1131	361	1160	383	1185	403	1211	424	1238	446
45000	4907	963	265	992	283	1027	306	1056	326	1083	346	1111	367	1141	390	1168	412	1191	431	1221	456	1246	478
48500	5289	973	285	1006	308	1035	329	1066	352	1092	371	1122	396	1150	419	1175	440	1202	463	1229	488	1253	510
52000	5671	984	308	1013	329	1043	352	1076	378	1103	400	1132	424	1155	444	1182	469	1211	495	1237	520	1260	542
55500	6052	997	333	1025	354	1054	378	1085	403	1111	426	1138	450	1167	476	1193	501	1220	528	1245	552	1271	579
59000	6434	1010	358	1039	382	1070	408	1096	432	1124	457	1150	482	1178	508	1203	533	1229	560	1252	585	1277	611
62500	6816	1021	383	1052	409	1079	434	1107	460	1137	489	1162	514	1188	540	1216	569	1237	593	1263	621		
66000	7197	1032	408	1064	437	1092	464	1120	491	1149	521	1173	546	1198	573	1224	602	1252	633	1273	658		

784 DH				Inlet diameter: 45" O.D.				Wheel diameter: 78¼"															
				Outlet area: 11.06 sq. ft. inside				Wheel circumference: 20.49 ft.															
CFM	OV	26"SP		28"SP		30"SP		32"SP		34"SP		36"SP		38"SP		40"SP		42"SP		44"SP		46"SP	
		RPM	BHP	RPM	BHP	RPM	BHP	RPM	BHP	RPM	BHP	RPM	BHP	RPM	BHP	RPM	BHP	RPM	BHP	RPM	BHP	RPM	BHP
46000	4159	861	272	888	292	917	314	947	339	971	360	997	382	1024	406	1048	428	1072	452	1098	478	1120	500
50000	4521	868	294	897	317	927	342	952	363	978	387	1006	413	1031	437	1057	463	1080	487	1105	513	1125	534
54000	4882	875	316	905	341	933	366	960	391	988	417	1014	443	1037	467	1062	493	1088	522	1110	547	1134	574
58000	5244	887	343	915	368	942	393	970	421	993	445	1018	470	1043	498	1070	528	1095	556	1116	581	1138	608
62000	5606	895	367	924	395	949	421	976	448	1002	475	1028	505	1053	532	1078	563	1101	590	1125	620	1146	647
66000	5967	905	394	933	422	960	451	985	479	1012	509	1038	539	1061	567	1085	597	1107	625	1130	655	1153	686
70000	6329	916	423	941	449	969	481	994	509	1023	543	1047	573	1069	601	1092	632	1116	664	1138	694	1161	726
74000	6691	925	450	953	482	978	511	1004	543	1032	578	1055	608	1080	640	1102	671	1125	703	1146	733		
78000	7052	937	482	965	515	989	545	1014	577	1041	612	1063	642	1087	675	1111	710	1137	748	1156	778		

854 DH				Inlet diameter: 49" O.D.				Wheel diameter: 85¼"															
				Outlet area: 13.13 sq. ft. inside				Wheel circumference: 22.32 ft.															
CFM	OV	26"SP		28"SP		30"SP		32"SP		34"SP		36"SP		38"SP		40"SP		42"SP		44"SP		46"SP	
		RPM	BHP	RPM	BHP	RPM	BHP	RPM	BHP	RPM	BHP	RPM	BHP	RPM	BHP	RPM	BHP	RPM	BHP	RPM	BHP	RPM	BHP
50000	3808	784	298	811	322	836	346	863	372	887	397	913	425	936	450	960	477	979	501	1006	533	1028	560
55000	4189	792	326	817	350	843	377	868	403	894	431	917	458	942	488	964	514	987	543	1006	568	1031	601
60000	4570	799	353	825	380	849	407	875	437	900	465	925	496	948	525	969	551	990	579	1012	610	1035	642
65000	4950	805	381	832	411	858	441	882	470	905	498	932	534	954	562	977	594	996	622	1021	658	1042	690
70000	5331	813	411	839	441	866	474	889	504	913	536	939	571	959	600	984	636	1006	669	1025	699	1045	731
75000	5712	823	444	850	478	876	512	898	541	921	574	945	609	967	642	991	678	1011	711	1033	747	1056	786
80000	6093	832	477	860	514	885	549	908	583	930	615	953	651	975	684	1000	726	1020	759	1041	795	1062	833
85000	6474	843	513	869	551	893	586	918	624	939	657	961	693	985	731	1009	773	1028	807	1048	842	1068	881
90000	6855	852	549	878	588	903	627	927	665	950	703	972	739	994	778	1017	820	1035	854	1057	896		

Performance certified is for installation Type D: Ducted inlet, Ducted outlet. Power rating (BHP) does not include transmission losses. Performance ratings do not include the effects of appurtenances (accessories).

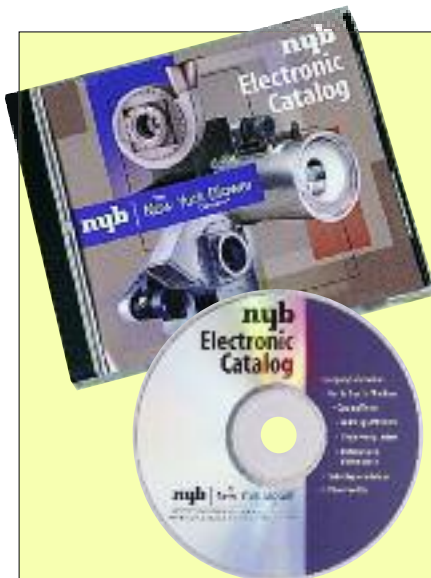

ELECTRONIC CATALOG

A complete New York Blower Catalog on one CD. No more manual calculations and bulky product catalogs. A critical tool for all system-designers and engineers who select and specify air-moving equipment.

SELECTION BENEFITS

- Fast, accurate fan selection.
- Automatic altitude, temperature, and density corrections.
- Sound levels by octave band.
- Fan-performance curves.
- Multiple model and size choices.
- Metric or English units.

CATALOG CONTENTS

- Fan-selection program.
- Complete product catalog in PDF including drawings, dimensions, and design specifications.
- Sample guide specifications.
- New York Blower Engineering Letters.
- Installation and Maintenance Manuals.
- Listing of New York Blower representatives.

To obtain your copy of New York Blower's Electronic Catalog contact your local New York Blower representative or go to www.nyb.com and click on *Selection Software*.

MATERIAL SPECIFICATIONS FOR STANDARD STEEL FANS

U.S. STANDARD STEEL GAUGE TO 7 GAUGE – DIMENSIONS [INCHES]

Size	Bare fan wt. [lbs.]	Housing					Wheel										Bearing base			Bearings		Type
		Side		Scroll	Inlet collar	LS/RIM				DH						Side sheets	Base flange	Top plates	Size			
		Sheets	Plates			Blades	Rims	Wts. [lbs.]	WR ²	Front plate	Back plate	Blade	Wts. [lbs.]	WR ²	LS/RIM				DH			
			Drive	Inlet	LS/RIM											DH						
224	560	7	10	10	7	7	7	-	42	13	10	7	10	63	21	1/4	1/4	3/8	23/16	23/16	D	
264	795	7	10	10	7	7	1/4	-	74	31	10	7	10	79	37	1/4	1/4	3/8	27/16	27/16	D	
294	1050	1/4	10	10	1/4	7	1/4	-	93	49	7	7	10	104	70	1/4	1/4	3/8	21 1/16	21 1/16	D	
334	1445	1/4	-	10	1/4	7	1/4	-	129	85	7	1/4	10	158	120	3/8	3/8	1/2	21 5/16	21 1/16	D	
364	1745	1/4	-	7	1/4	7	1/4	-	150	113	7	1/4	10	186	180	3/8	3/8	1/2	21 5/16	21 5/16	G	
404	2115	1/4	-	7	1/4	7	1/4	1/4	288	391	1/4	1/4	7	263	330	3/8	3/8	1/2	37/16	21 5/16	G	
454	2860	1/4	-	7	1/4	7	3/8	1/4	474	898	1/4	1/4	7	352	520	3/8	3/8	1/2	31 5/16	37 1/16	G	
504	3490	1/4	-	7	1/4	7	3/8	1/4	570	1223	1/4	1/4	7	424	812	3/8	1/2	1/2	31 5/16	31 5/16	G	
574	4575	1/4	-	7	1/4	7	3/8	1/4	752	2586	1/4	3/8	7	657	1635	3/8	5/8	1/2	47/16	31 5/16	G	
644	5750	1/4	-	1/4	1/4	1/4	3/8	1/4	1056	3451	1/4	3/8	1/4	866	2765	3/8	5/8	1/2	41 5/16	47 1/16	G	
714	6795	1/4	-	1/4	1/4	1/4	3/8	1/4	1237	4967	1/4	3/8	1/4	1127	4152	3/8	5/8	1/2	57/16	41 5/16	G	
784	7975	1/4	-	1/4	1/4	1/4	3/8	1/4	1565	7648	1/4	3/8	1/4	1319	6032	3/8	5/8	1/2	57/16	41 5/16	G	
854	9320	1/4	-	1/4	1/4	1/4	3/8	1/4	1798	9763	1/4	3/8	1/4	1533	8504	3/8	5/8	1/2	6	57/16	G	

D – Link-Belt P-300.

G – Link-Belt P-LB6800.

nyb reserves the right to substitute bearings of equal rating.

1. All sheet and plate steel is AISI 1017.
2. Wheel hubs are cast steel or fabricated steel.
3. Alternate materials or coatings may require changes in specifications.
4. Shafting is ASTM A-108, grade 1045 turned, ground, polished and straightened.

FLANGED INLET OPTION

Furnished with holes starting on vertical centerline.

Inlet bar sizes:

- Sizes 224-364..... 1/4 x 1 1/2
- Sizes 404-854..... 1/4 x 2

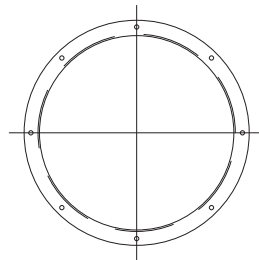

FLANGED OUTLET OPTION

Holes furnished on 4" centers on centerline.

Outlet flange sizes:

- Sizes 224-364... 1 1/2 x 1 1/2 x 3/16
- Sizes 404-854... 2 x 2 x 3/16

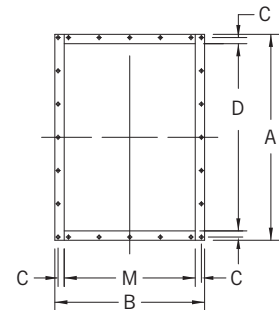

On Size 144 scroll side, holes are furnished on 2 7/16" centers.

DIMENSIONS [INCHES]

Size	I.D.*	B.C.	O.D.	Holes	
				No.	Dia.
224	12 5/8	14 1/2	16	8	7/16
264	14 5/8	16 1/2	18	8	7/16
294	16 5/8	18 1/2	20	8	7/16
334	18 5/8	20 1/2	22	16	7/16
364	20 5/8	22 1/2	24	16	7/16
404	22 5/8	25	27	16	9/16
454	25 5/8	28	30	16	9/16
504	28 5/8	31	33	16	9/16
574	32 5/8	35	37	16	9/16
644	36 1/2	39	41	24	9/16
714	40 1/2	43	45	24	9/16
784	44 1/2	47	49	24	9/16
854	48 1/2	51	53	24	9/16

*Dimension shown is I.D. of inlet collar.

DIMENSIONS [INCHES]

Size	A	B	C	D*	M*	Holes	
						No.	Dia.
224	16	13 3/4	7/8	13	10 3/4	12	7/16
264	17 15/16	15 3/8	7/8	14 15/16	12 3/8	16	7/16
294	19 7/8	17	7/8	16 7/8	14	16	7/16
334	21 3/4	18 5/8	7/8	18 3/4	15 5/8	16	7/16
364	23 11/16	20 1/4	7/8	20 11/16	17 1/4	20	7/16
404	26 13/16	23	1 1/8	22 13/16	19	24	9/16
454	29 11/16	25 3/8	1 1/8	25 11/16	21 3/8	24	9/16
504	32 11/16	27 7/8	1 1/8	28 11/16	23 7/8	24	9/16
574	36 5/8	31 1/8	1 1/8	32 5/8	27 1/8	32	9/16
644	40 5/8	34 1/2	1 1/8	36 5/8	30 1/2	32	9/16
714	44 3/8	37 5/8	1 1/8	40 3/8	33 5/8	36	9/16
784	48 3/8	40 7/8	1 1/8	44 3/8	36 7/8	40	9/16
854	52 1/4	44 1/8	1 1/8	48 1/4	40 1/8	44	9/16

*Dimension shown is inside flange, outside outlet. Deduct housing material thickness to determine inside dimension of discharge.

DIMENSIONS

M and D are outside housing dimensions.
L dimension is inlet I.D.
J is from housing side over flange.
Arrangement 8 requires special base dimensions.
Dimensions not to be used for construction unless certified.
Tolerance: $\pm 1/8"$

ARRANGEMENT 1

SIZES 224-294

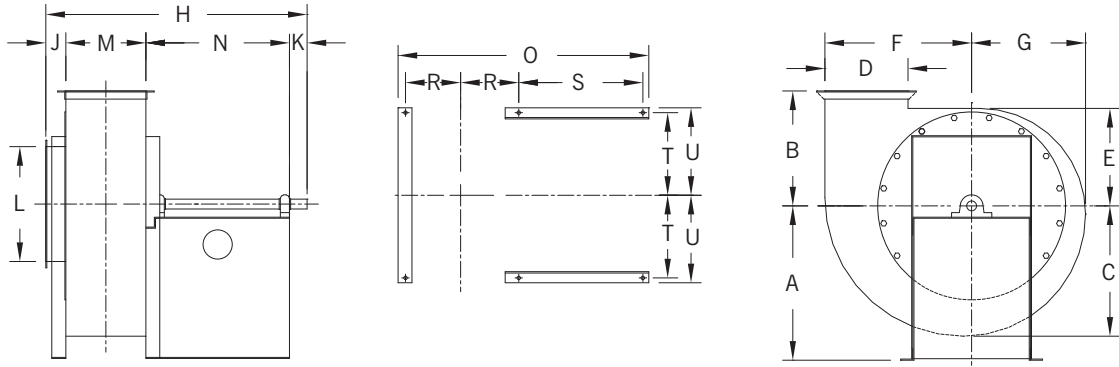

DIMENSIONS [INCHES]

Size	Wheel dia.	A	B	C	D	E	F	G	H	J	K	L	M
224	22 ⁵ / ₈	25 ¹ / ₂	16 ¹ / ₂	18 ⁷ / ₈	13	14	21 ¹ / ₄	16 ³ / ₈	44 ⁵ / ₈	3 ³ / ₈	5	12 ⁵ / ₈	10 ³ / ₄
264	26 ¹ / ₈	28	18 ¹ / ₂	21 ³ / ₄	15	16 ¹ / ₈	24 ¹ / ₂	18 ⁷ / ₈	46 ³ / ₄	4 ³ / ₈	5 ¹ / ₂	14 ⁵ / ₈	12 ³ / ₈
294	29 ⁵ / ₈	32 ¹ / ₂	21	24 ⁵ / ₈	16 ⁷ / ₈	18 ¹ / ₄	27 ³ / ₄	21 ³ / ₈	48 ⁷ / ₈	4 ³ / ₈	6	16 ⁵ / ₈	14

Size	N	O	R	S	T	U	a	b	c	d	Shaft dia.	Keyway	Base holes
224	22 ¹ / ₂	36 ³ / ₈	7	19 ³ / ₈	10 ⁷ / ₈	11 ³ / ₄	17 ⁵ / ₈	26 ⁵ / ₈	20	15 ¹ / ₄	2 ³ / ₁₆	1/2 x 1/4	9/16
264	24 ¹ / ₂	41	8 ³ / ₈	20 ³ / ₈	12 ¹ / ₄	13 ¹ / ₈	20 ¹ / ₄	30 ³ / ₈	23	17 ¹ / ₂	2 ⁷ / ₁₆	5/8 x 5/16	3/4
294	24 ¹ / ₂	42 ⁵ / ₈	9 ¹ / ₈	20 ³ / ₈	13 ⁵ / ₈	14 ¹ / ₂	23	34 ³ / ₈	26 ¹ / ₈	19 ⁷ / ₈	2 ¹¹ / ₁₆	5/8 x 5/16	3/4

ARRANGEMENT 1

SIZES 334-454

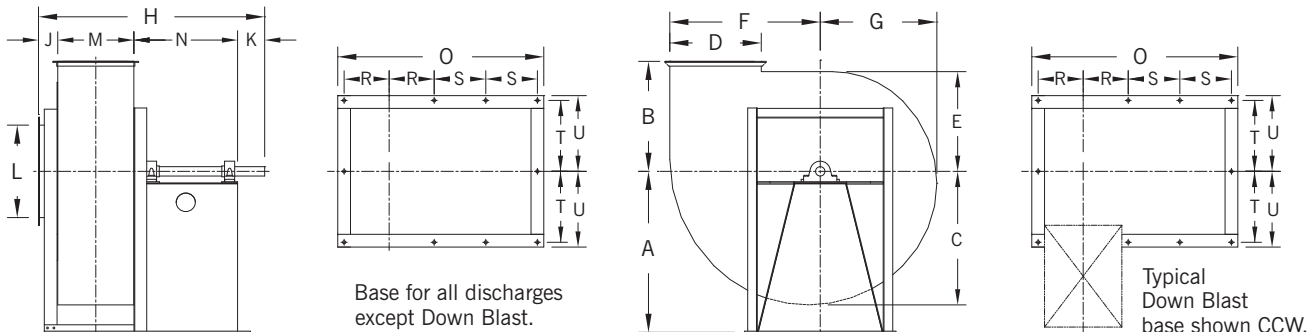

DIMENSIONS [INCHES]

Size	Wheel dia.	A	B	C	D	E	F	G	H	J	K	L	M	N	O	R
334	33	32 ³ / ₄	23	27 ³ / ₈	18 ³ / ₄	20 ³ / ₈	30 ⁷ / ₈	23 ⁷ / ₈	52 ¹ / ₂	4 ³ / ₈	6 ¹ / ₂	18 ⁵ / ₈	15 ⁵ / ₈	26	49 ³ / ₄	9 ⁷ / ₈
364	36 ¹ / ₂	36 ¹ / ₄	25 ¹ / ₂	30 ¹ / ₄	20 ³ / ₄	22 ¹ / ₂	34 ¹ / ₈	26 ³ / ₈	56 ¹ / ₄	5 ¹ / ₂	7	20 ⁵ / ₈	17 ¹ / ₄	26 ¹ / ₂	54	11 ¹ / ₄
404	40	40	28	33 ¹ / ₄	22 ⁷ / ₈	24 ³ / ₄	37 ³ / ₈	29	60 ¹ / ₂	5 ¹ / ₂	7 ¹ / ₂	22 ⁵ / ₈	19	28 ¹ / ₂	57 ³ / ₄	12 ¹ / ₈
454	45 ¹ / ₈	45	31 ¹ / ₂	37 ¹ / ₂	25 ³ / ₄	27 ⁷ / ₈	42 ¹ / ₄	32 ⁵ / ₈	65 ³ / ₈	5 ¹ / ₂	8	25 ⁵ / ₈	21 ³ / ₈	30 ¹ / ₂	62 ¹ / ₈	13 ³ / ₈

Size	S	T	U	a	b	c	d	Shaft diameter		Keyway		Base holes
								LS/RIM	DH	LS/RIM	DH	
334	13	15 ⁷ / ₈	17 ⁵ / ₈	25 ³ / ₄	38 ¹ / ₈	29 ¹ / ₄	22 ³ / ₈	2 ¹⁵ / ₁₆	2 ¹¹ / ₁₆	5/8 x 5/16	5/8 x 5/16	3/4
364	13 ¹ / ₄	17 ¹ / ₂	19 ³ / ₄	28 ¹ / ₂	42 ¹ / ₈	32 ¹ / ₄	24 ⁵ / ₈	2 ¹⁵ / ₁₆	2 ¹⁵ / ₁₆	5/8 x 5/16	5/8 x 5/16	7/8
404	14 ¹ / ₄	19 ³ / ₈	21 ⁵ / ₈	31 ¹ / ₈	46 ¹ / ₄	35 ³ / ₈	27	3 ⁷ / ₁₆	2 ¹⁵ / ₁₆	7/8 x 7/16	5/8 x 5/16	7/8
454	15 ¹ / ₈	21 ¹ / ₄	23 ¹ / ₂	35 ³ / ₈	52 ¹ / ₄	40	30 ⁵ / ₈	3 ¹⁵ / ₁₆	3 ⁷ / ₁₆	7/8 x 7/16	3/4 x 3/8	7/8

FAN DISCHARGES – VIEWED FROM DRIVE SIDE

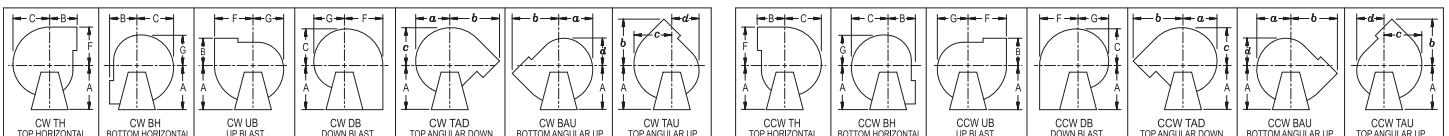

Clockwise—angular discharges at 45°

Counterclockwise—angular discharges at 45°

ARRANGEMENT 1

SIZES 504-644

DIMENSIONS

M and D are outside housing dimensions.
L dimension is inlet I.D.
J is from housing side over flange.

Arrangement 8 requires special base dimensions.

Dimensions not to be used for construction unless certified.

Tolerance: $\pm 1/8"$

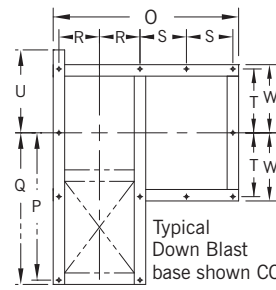
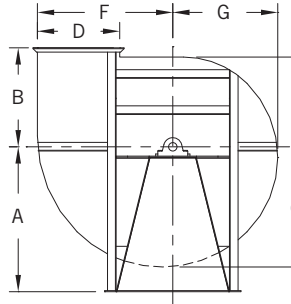
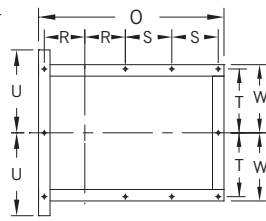
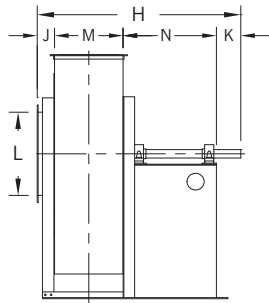

Base for all discharges except Down Blast.

Typical Down Blast base shown CCW.

DIMENSIONS [INCHES]

Size	Wheel dia.	A	B*	C	D	E	F	G	H	J	K	L	M	N	O	P	Shaft diameter				Keyway		Base holes									
																	RIM	DH	RIM	DH												
504	50 1/2	50 1/2	34 1/2	42	28 3/4	31 1/4	47 1/4	36 5/8	71 1/8	6 1/4	8 1/2	28 5/8	23 7/8	32 1/2	64 3/8	49 1/4	51 1/4	14	16 1/4	22 1/4	31 3/8	24 1/4	39 3/8	57 3/4	44 5/8	34 1/8	31 5/16	31 5/16	1 x 1/2	1 x 1/2	1	
574	57 1/2	57 1/2	39	47 5/8	32 5/8	35 5/8	53 5/8	41 5/8	77 5/8	7 1/4	9	32 5/8	27 1/8	34 1/4	71 3/8	56 1/8	58 5/8	16 1/8	17 1/8	25	35 3/4	27 1/2	44 3/4	65 5/8	50 3/4	38 3/4	47 1/16	31 5/16	31 5/16	1 x 1/2	1 x 1/2	1
644	64 3/8	64	43	53 3/8	36 5/8	39 7/8	60 1/8	46 5/8	84 1/2	7 1/2	9 1/2	36 1/2	30 1/2	37	77 1/2	62 3/8	65 1/8	17 3/4	18 1/2	30	39 1/8	32 1/2	50 1/4	72 7/8	57	43 1/2	41 5/16	47 1/16	1 1/4 x 5/8	1 x 1/2	1	

*For Down Blast discharge, use A dimension for B.

ARRANGEMENT 1

SIZES 714-854

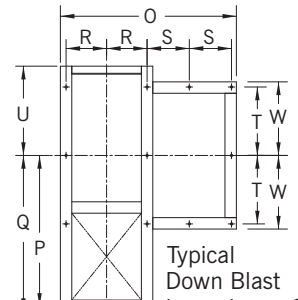
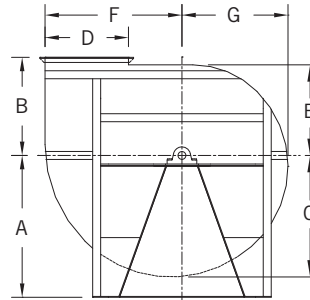
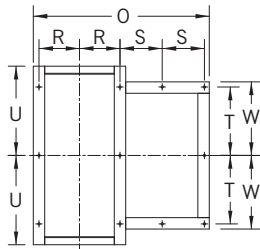
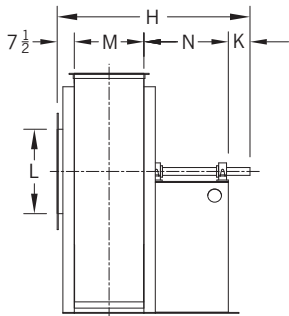

Base for all discharges except Down Blast.

Typical Down Blast base shown CCW.

DIMENSIONS [INCHES]

Size	Wheel dia.	A							B	C	D	E	F	G	H	K	L	M	N
		TH	BH	UB	DB	TAD	BAU	TAU											
714	71 1/4	54	71	61 1/2	47 1/2	50	65	57 1/2	47 1/2	59	40 3/8	44 1/8	66 1/2	51 1/2	91 1/8	10	40 1/2	33 5/8	40
784	78 1/4	59	77	67	52	54 3/4	71	63	52	64 5/8	44 3/8	48 3/8	73	56 5/8	98 7/8	10 1/2	44 1/2	36 7/8	44
854	85 1/4	64	83	73	57	60	78 1/2	69	57	70 1/2	48 1/4	52 5/8	79 1/2	61 5/8	106 5/8	11	48 1/2	40 1/8	48

Size	O	P	Q	R	S	T	U	W	a	b	c	d	Shaft diameter		Keyway	Base holes
													RIM	DH		
714	83 1/4	69	71 1/2	19 3/8	20	33 1/2	43 1/2	35 3/4	55 1/2	80 5/8	62 7/8	48	57 1/16	41 5/16	1 1/4 x 5/8	1
784	90 1/2	75 1/2	78	21	22	36 1/2	47	38 3/4	60 7/8	88 1/2	69	52 3/4	57 1/16	41 5/16	1 1/4 x 5/8	1
854	97 3/4	82	84 1/2	22 1/2	24	39 1/2	50 1/2	41 3/4	66 3/8	96 5/8	75	57 3/8	6	57 1/16	1 1/4 x 5/8	1

FAN DISCHARGES – VIEWED FROM DRIVE SIDE

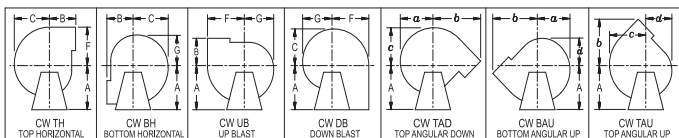

Clockwise—angular discharges at 45°

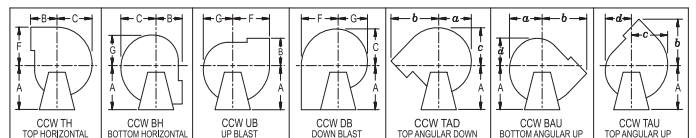

Counterclockwise—angular discharges at 45°

COMPLETE SELECTION OF AIR-MOVING EQUIPMENT

The New York Blower Company offers thousands of different types, models, and sizes of air-moving equipment. Contact your nyb representative for assistance in identifying the best fan for your application.



AIR-HANDLING [AXIAL]

For the ideal handling of clean to moderately dirty airstreams. Commercial and industrial HVAC, drying and cooling systems, fume extraction, and process-heat removal are typical applications.



FIBERGLASS REINFORCED PLASTIC [FRP]

Choice of performance and duty for corrosive gas streams. Applications include chemical process, wastewater treatment, laboratory hood exhaust, and tank aeration.



DUST/MATERIAL HANDLING

Wide range of duty available with unique fan lines capable of handling light dust to heavy material. Typical applications include dust-collection and high-pressure process along with material-conveying.



AIR-HANDLING [CENTRIFUGAL]

Designed for clean to moderately dirty gas streams. Commercial and industrial HVAC, process cooling, light material-conveying, heat removal, and dryer exhaust are just a few of the numerous sample applications.

CUSTOM PRODUCTS

Designed for unique applications. Variety of configurations, temperatures, flows, and pressures. Wide range of modifications and accessories are available to meet the most demanding specifications.



Leading the industry forward since 1889



ROOF VENTILATORS

Including both hooded and upblast ventilators, propeller fans, and centrifugal roof exhausters. These units are ideal for industrial, commercial, and institutional applications.



HEATING PRODUCTS

Industrial-duty steam unit heaters with steam heating coils are available for facility heating and process-heat transfer.



PROCESS/FAN COMPONENTS

Plug fans, plenum fans, wheels, inlet cones, and housings for a wide variety of OEM applications. Process/fan components are used in air-handling units, ovens, dryers, freezer tunnels, and filtration systems.