



THE NEW YORK BLOWER COMPANY
7660 Quincy Street
Willowbrook, IL 60527-5530

Visit us on the Web: <http://www.nyb.com>
Phone: (800) 208-7918 Email: nyb@nyb.com

INSTALLATION
MAINTENANCE,
OPERATING
INSTRUCTIONS

IM-120

DUCT FANS – INDUSTRIAL DUCT FANS - TUBEAXIAL FANS - VANEAXIAL FANS -TUBULAR CENTRIFUGAL FANS – VANEAXIAL FIXED PITCH FANS VANEAXIAL ADJUSTABLE PITCH FANS



WORD ABOUT SAFETY

Beginning in June 2012, the above **WARNING** signage has been placed on all **nyb** fans, as specified by ISO and recommended by the European Union. Air moving equipment involves electrical wiring, moving parts, sound, and air velocity or pressure which can create safety hazards if the equipment is not properly installed, operated and maintained. To minimize this danger, follow these instructions as well as the additional instructions and warnings on the equipment itself.

All installers, operators and maintenance personnel should study AMCA Publication 410, "Recommended Safety Practices for Air Moving Devices", which is included as part of every shipment. Additional copies can be obtained by writing to New York Blower Company, 7660 Quincy St., Willowbrook, IL 60527.

ELECTRICAL DISCONNECTS

Every motor driven fan should have an independent disconnect switch to isolate the unit from the electrical supply. It should be near the fan and must be capable of being locked by maintenance personnel while servicing the unit, in accordance with OSHA or equivalent safety procedures.

MOVING PARTS

All moving parts must have guards to protect personnel. Safety requirements vary, so the number and type of guards needed to meet company, local and National Safety standards must be determined and specified by the user. Never start a fan without having all safety guards installed. Check regularly for damaged or missing guards and do not operate any fan with guards removed. Fans can also become dangerous because of potential "windmilling", even though all electrical power is disconnected. Always block the rotating assembly before working on any moving parts.

SOUND

Some fans can generate sound that could be hazardous to exposed personnel. It is the responsibility of the system designer and user to determine sound levels of the system, the degree of personnel exposure, and to comply with applicable safety requirements to protect personnel from excessive noise. Consult **nyb** for fan sound power level ratings.

AIR PRESSURE AND SUCTION

In addition to the normal dangers of rotating machinery, fans present another hazard from the suction created at the fan inlet. This suction can draw materials into the fan where they become high velocity projectiles at the outlet. It can also be extremely dangerous to persons in close proximity to the inlet, as the forces involved can overcome the strength of most individuals. Inlets and outlets that are not ducted should be screened to prevent entry and discharge of solid objects.



Danger: Do Not Enter/Confined Space

ACCESS DOORS

The above **DANGER** decal is placed on all **nyb** cleanout doors. These doors, as well as access doors to the duct system, should never be opened while the fan is in operation. Serious injury could result from the effects of air pressure or suction. Quick-opening doors must have the door handle bolts securely tightened to prevent accidental or unauthorized opening. Bolted doors must be tightened for the same reason.

RECEIVING AND INSPECTION

The fan and accessories should be inspected on receipt for any shipping damage. Turn the wheel by hand to see that it rotates freely and does not bind. If dampers or shutters are provided, check these accessories for free operation of all moving parts. F.O.B. factory shipping terms require that the receiver be responsible for inspecting the equipment upon arrival. Note damage or shortages on the Bill of Lading and file any claims for damage or loss in transit. **nyb** will assist the customer as much as possible; however, claims must be originated at the point of delivery.

HANDLING

Fans should be lifted by the base, mounting supports, or lifting eyes only. Never lift a fan by the wheel, shaft, motor, motor bracket, housing inlet, outlet, or any fan part not designed for lifting. A spreader should be used to avoid damage.

On direct drive fans, lifting holes are provided in the motor base to assist in handling the fan assembly. These lifting holes should be used in conjunction with the lifting eyes/lugs when lifting and positioning the fan onto its foundation. A heavy round steel bar or appropriate fixture can be passed through the lifting holes to simplify attachment of the lifting device. Be sure to follow all local safety codes when moving heavy equipment.

STORAGE

Whenever possible, fans and accessories should be stored in a clean, dry location to prevent rust and corrosion of steel components. If outdoor storage is necessary, protection should be provided. Cover the inlet and outlet to prevent the accumulation of dirt and moisture in the housing. Cover motors with water-proof material. Remove any fan and motor drain plugs to minimize moisture buildup. Refer to motor manufacturer's IM manual for further motor storage instructions.

Any stored bearing can be damaged by condensation caused by temperature variations. Therefore, **nyb** fan bearings are filled with grease at the factory to exclude air and moisture. Such protection is adequate for shipment and subsequent immediate installation and operation.

For long term or outdoor storage, mounted bearings should be immediately regreased and wrapped with plastic for protection. Split housed bearings may require additional grease to completely fill the bearing housing cavity. **Rotate the fan wheel and motor shaft by hand at least every two weeks to redistribute grease on internal bearing parts.** Each month the fan and motor bearings should be purged with new grease to remove condensation, since even a filled bearing can accumulate moisture. Use caution when purging, as excessive pressure can damage the seals. Rotate the shaft while slowly adding grease.

For Belt-Driven units, belts should be slacked to prevent damage to shaft, belts, and bearings.

Check shutters for free operation and lubricate moving parts prior to storage. Inspect the stored unit periodically to ensure the above precautionary storage measures are still intact.

Prior to start-up, split housed bearings should have excess grease removed such that the grease level is level with the bottom of the shaft.

FAN INSTALLATION

nyb wheels are dynamically balanced when fabricated. Fully assembled fans are test run at operating speeds to check the entire assembly for conformance to **nyb** vibration limits. Nevertheless, all units must be adequately supported for smooth operation. **Ductwork or stacks should be independently supported as excess weight may distort the fan housing and cause contact between moving parts.** Where vibration isolators are used, consult the **nyb** certified drawing for proper location and adjustment. [Access panels should be provided in the ductwork immediately adjacent to the fan inlet and outlet to facilitate inspection and maintenance of internal parts.]

Slab-Mount Units

A correctly designed and level concrete foundation provides the best means of installing floor-mounted fans. The mass of the base must maintain the fan/driver alignment, absorb normal vibration, and resist lateral loads. The overall dimensions of the concrete base should extend at least six inches beyond the base of the fan. The weight of the slab should be two to three times the weight of the rotating assembly, including the motor. The foundation requires firmly anchored fasteners such as the anchor bolts shown in Figure 1. Hammer-drilled expansion fasteners can be used in less demanding applications.

Move the fan to the mounting location and lower it over the anchor bolts, leveling the fan with shims around the bolts. Fasten the fan securely. When grout is used, shim the fan at least 3/4-inch from the concrete base. (See Figure 1.) When isolation is used, check the **nyb** certified drawing for installation instructions.

Elevated Units

When an elevated or suspended structural steel platform is used, it must have sufficient bracing to support the unit load and prevent side sway. The platform should be of welded construction to maintain permanent alignment of all members.

Duct Mounted Units

Duct mounted units may be mounted directly to the duct system in any position provided the supporting duct is structurally adequate. Mount the fan to the duct with the appropriate bolts.

Roof Mounted Units

Before mounting roof mounted units, the curb must be prepared. For details, see Figure 2.

Move the roof mounted fan to its mounting location and lower it over the curb. Tap the curb cap until the unit rests flat on the curb. Using 3/8" lag screws with neoprene washers and flat washers, anchor the unit to the curb.

Guy wire bracing must be provided when necessary on large roof mounted units to prevent side sway.

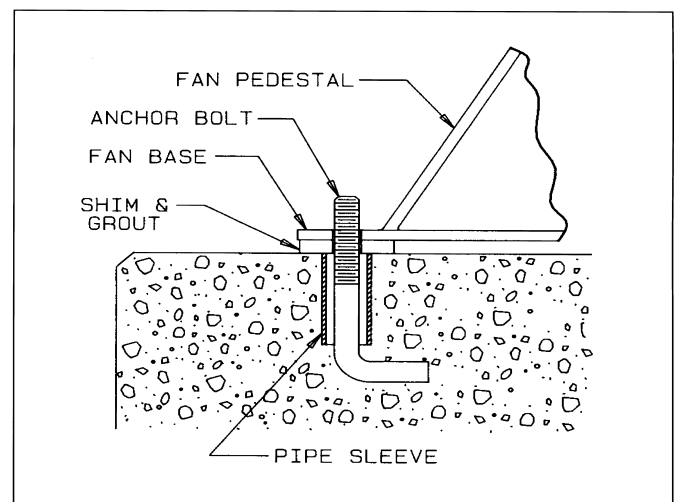

Figure 1

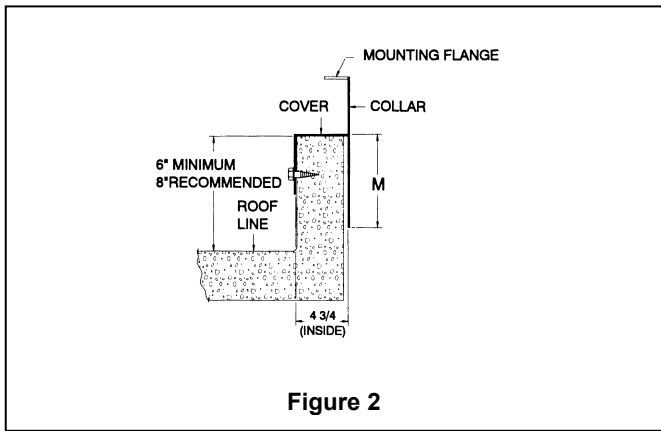

Figure 2

M- Dimension

- Tubular Centrifugal Fans:
 Sizes 12 → 22 – 4 1/2", 24 → 49–5", 54 → 73 – 6"
- Duct, Tubeaxial, and Vaneaxial Fans:
 Sizes 12 → 27 – 4 1/2", 29 → 60 – 5"
- Vaneaxial Fixed Pitch Fans:
 Sizes 12 → 29 – 4 1/2", 32 → 60 – 5"
- Vaneaxial Fixed Pitch Fans:
 Sizes 12 → 29 – 4 1/2", 32 → 60 – 5"

V-BELT DRIVE

Installation

1. Remove all foreign material from the fan and motor shafts. Coat shafts with machine oil for easier mounting. Mount the belt guard backplate at this time if partial installation is required prior to sheave mounting.
2. Mount sheaves on shafts after checking sheave bores and bushings for nicks or burrs. Avoid using force. If resistance is encountered, lightly polish the shaft with emery cloth until the sheave slides on freely. Tighten tapered bushing bolts sequentially so that equal torque is applied to each.
3. Adjust the motor on its base to a position closest to the fan shaft. Install belts by working each one over the sheave grooves until all are in position. Never pry the belts into place. Sufficient motor adjustment is provided for easy installation of the proper size belts.
4. Adjust sheaves so that the sheave faces are in the same plane. Check this by placing a straightedge across the faces of the sheaves. Any gap between the edge and sheave faces indicates misalignment. **IMPORTANT:** This method is only valid when the width of the surface between the belt edge and the sheave face is the same for both sheaves. When they are not equal, or when using adjustable-pitch sheaves, adjust so that all belts have approximately equal tension. Both shafts should be at right angles to the center belt. Tighten the tapered bushing bolts sequentially so that equal torque is applied to each.

Belt Tensioning

1. Check belt tension with a tensioning gage and adjust using the positive screw adjustment feature. Excess tension shortens bearing life while insufficient tension shortens belt life, can reduce fan performance and may cause vibration. The lowest allowable tension is that which prevents slippage under full load. Belts may slip during start-up, but slipping should stop as soon as the fan reaches full speed. For more precise tensioning methods, consult the drive manufacturer's literature.

2. Recheck setscrews, rotate the drive by hand and check for rubbing. Complete the installation by installing the belt guard.
3. Belts tend to stretch somewhat after installation. Recheck tension after several days of operation. Check sheave alignment as well as setscrew and/or bushing bolt tightness.

START-UP

A start-up checklist is available on nyb's Maintenance manuals page under the support tools menu, [Click Here](#). Safe operation and maintenance includes the selection and use of appropriate safety accessories for the specific installation. This is the responsibility of the system designer and requires consideration of equipment location and accessibility as well as adjacent components. All safety accessories must be installed properly prior to start-up.

Safe operating speed is a function of system temperature and wheel design. Do not under any circumstances exceed the maximum safe fan speed published in the **nyb** bulletin, which is available from your **nyb** field sales representative.

Procedure

1. If the drive components are not supplied by **nyb**, verify with the manufacturer that the motor's starting torque is adequate for the speed and inertia of the fan.
2. Inspect the installation prior to starting the fan. Check for any loose items or debris that could be drawn into the fan or dislodged by the fan discharge. Check the interior of the fan as well. Turn the wheel by hand to check for binding.
3. Check drive installation and belt tension.
4. Check the tightness of all setscrews, nuts and bolts. When furnished, tighten hub setscrews with the wheel oriented so that the setscrew is positioned underneath the shaft.
5. Install all remaining safety devices and guards. Verify that the supply voltage is correct and wire the motor. "Bump" the starter to check for proper wheel rotation.
6. Check to ensure that neither the fan nor motor shaft are rotating.
7. Use extreme caution when testing the fan with ducting disconnected. Apply power and check for unusual sounds or excessive vibration. If either exists, see the section on Common Fan Problems. To avoid motor overload, do not run the fan for more than a few seconds if ductwork is not fully installed. Without the ductwork attached, normal operating speed may not be obtained without motor overload. Once ductwork is attached, check for correct fan speed and complete installation. Ductwork and guards must be fully installed for safety.
8. All wheel, sheave, and coupling setscrews should be rechecked after a few minutes, eight hours and two weeks of operation (see Tables 1 & 2 for correct tightening torques).

NOTE: Shut the fan down immediately if there is any sudden increase in fan vibration.

Table 1 - WHEEL SETSCREW TORQUES

Setscrew Size Diameter (in.)	Carbon Steel Setscrew Torque*	
	lb.-in.	lb.-ft.
1/4	75	6.2
5/16	144	12
3/8	252	21
7/16	396	33
1/2	600	50
5/8	1164	97
3/4	2016	168
7/8	3204	267
1	4800	400

* Stainless Steel setscrews are not hardened and should not be tightened to more than 1/2 the values shown.

Table 2 - BEARING SETSCREW TORQUE, lb.-in.

Setscrew Diameter	Manufacturer				
	Link-Belt	Sealmaster	SKF	McGill	Dodge
#10	40	--	35	35	--
1/4	90	65	50	85	--
5/16	185	125	165	165	160
3/8	325	230	290	290	275
7/16	460	350	350	--	--
1/2	680	500	620	--	600
5/8	1350	1100	1325	--	1200
3/4	2350	--	--	--	2000

Fan Shutoff for Fans with Elevated Airstream Temperatures (Greater than 200 °F)

High temperature, rotating equipment such as fans must be protected from "heat soaking". Fan wheels must be rotating whenever the airstream temperature is above 200°F. to prevent the shaft from "sagging" causing a permanent bend in the shaft. After the airstream temperature has fallen below 200°F, the fan can be shutdown. Start-up and shut down procedures are required to prevent this. If a power failure occurs, rotate the shaft manually if necessary.

If a shaft is bent due to heat soaking or binding a sudden increase in fan vibration will occur. The shaft will need to be removed, checked for straightness and straightened or replaced.

FAN MAINTENANCE

nyb fans are manufactured to high standards with quality materials and components. Proper maintenance will ensure a long and trouble-free service life.

Do not attempt any maintenance on a fan unless the electrical supply has been completely disconnected and locked. In many cases, a fan can windmill despite removal of all electrical power. The rotating assembly should be blocked securely before attempting maintenance of any kind.

The key to good fan maintenance is regular and systematic inspection of all fan parts. Inspection frequency is determined by the severity of the application and local conditions. Strict adherence to an inspection schedule is essential.

Regular fan maintenance should include the following:

1. Check the fan wheel for any wear or corrosion, as either can cause catastrophic failures. Check also for the build-up of material which can cause unbalance resulting in vibration, bearing wear and serious safety hazards. Clean or replace the wheel as required.
2. Check the V-belt drive for proper alignment and tension (see section on V-belt drives.) If belts are worn, replace them as a set, matched to within manufacturer's tolerances.
3. Lubricate the bearings, but do not over lubricate (see the bearing section for detailed specifications).
4. Ceramic-felt shaft seals require no maintenance, although worn seals should be replaced. When lip-type shaft seals are provided, lubricate them with "NEVER-SEEZ"

WARNING: Do not remove or loosen the fan hub from the fan wheel. Removing or loosening the fan hub from the fan wheel will cause imbalance and void the warranty.

5. During any routine maintenance, all setscrews and bolts should be checked for tightness. See the table for torques.
6. When installing a new Tubular Centrifugal wheel or inlet cone, the proper wheel-to-inlet cone clearance must be maintained (See Figure 3 for correct full-width wheel dimensions).
7. **WARNING:** When installing any new rotating components (wheel, shaft, bearings, coupling, drive components, or motor), it is recommended that the procedures in the Start-Up section are followed. Fan vibration readings should be taken and a trim balance be performed if excessive vibration is experienced.

BEARINGS

Storage

Any stored bearing can be damaged by condensation caused by temperature variations. Therefore, nyb fan bearings are filled with grease at the factory to exclude air and moisture. Such protection is adequate for shipment and subsequent immediate installation.

For long term or outdoor storage, mounted bearings should be regreased. **Rotate the fan wheel by hand at least every two weeks to redistribute grease on internal bearing parts.** Each month the bearings should be purged with new grease to remove condensation, since even a filled bearing can accumulate moisture. Use caution when purging, as excessive pressure can damage the seals. Rotate the shaft while slowly adding grease.

Operation

Check the setscrew torque before start-up (see table for correct values). Since bearings are completely filled with grease at the factory, they may run at an elevated temperature during initial operation. Surface temperatures may reach 180°F. and grease may bleed from the bearing seals. This is normal and no attempt should be made to replace lost grease. Bearing surface temperatures will decrease when the internal grease quantity reaches a normal operating level. Relubrication should follow the recommended schedule.

Disposal of material should be made in accordance with local government regulations.

WHEEL BALANCE

Airstreams containing particulate or chemicals can cause abrasion or corrosion of the fan parts. This wear is often uneven and can lead to significant wheel imbalance over time. When such wear is discovered, a decision must be made as to whether to rebalance or replace the wheel.

The soundness of all parts should be determined if the original thickness of components is reduced. Be sure there is no hidden structural damage. The airstream components should also be cleaned to remove any build-up of foreign material. Specialized equipment can be used to rebalance a cleaned wheel that is considered structurally sound.

Balance weights should be rigidly attached at a point that will not interfere with the housing nor disrupt airflow. Remember that centrifugal forces can be extremely high at the outer radius of a fan wheel. Welding is the preferred method of balance weight attachment. Be sure to ground the welder directly to the fan wheel. Otherwise, the welding current could pass through the fan bearings and damage them.

WARNING: Do not remove or loosen the fan hub from the fan wheel. Removing or loosening the fan hub from the fan wheel will cause imbalance and void the warranty.

FULL WIDTH TUBULAR CENTRIFUGAL FAN WHEEL-CONE CLEARANCES (contact nyb for partial width dimensions)

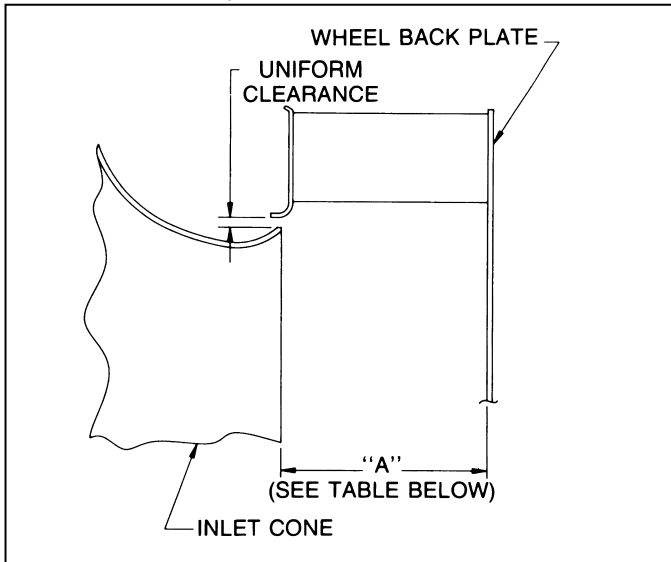

Figure 3

Fan Size	"A" Dimension	Fan Size	"A" Dimension
12	4 1/2	36	13 3/8
15	5 1/2	40	14 13/16
18	7	44	16 1/4
22	8 1/4	49	17 15/16
24	9 5/16	54	19 13/16
27	10 3/16	60	21 13/16
30	11 1/4	66	24
33	12 1/4	73	26 9/16

Lubrication

Use the table for relubrication scheduling according to operating speed and shaft diameter. Bearings should be lubricated with a premium quality lithium-based grease conforming to NLGI Grade 2. Examples are:

Mobil	-	Mobilgrease XHP 222
Mobil	-	Unirex N2
Mobil	-	SHC100
Exxon	-	Ronex MP
Shell	-	Gadus S2 V220

These greases are for fan bearing surface temperatures of 40°F. to 180°F. For surface temperatures of 181°F. to 230°F. use Mobilith SHC220. Do not use "high temperature" greases, as many are not formulated to be compatible with fan bearings.

Add grease to the fan bearings while running the fan or rotating the shaft by hand. Be sure all guards are in place if lubrication is performed while the fan is operating. Add just enough grease to cause a slight purging at the seals except on split pillowblocks. Completely filled fan bearings will run hotter until a sufficient amount of grease is purged out of the seals.

Split pillowblock bearings (Link-Belt P-LB6800 & P-LB6900, SKF SAF 22500, Dodge SAF-XT) should be cleaned and repacked at approximately every eighth lubrication interval. This requires removal of the bearing cap. Clean out old grease and repack the bearing with fresh grease. Pack the bearing fully and fill the housing reservoir to the bottom of the shaft on both sides of the bearing. Replace the bearing cap, being careful not to mix caps, as they are not interchangeable from one bearing to another. **Do not over lubricate split pillowblock bearings.**

Refer to your motor manufacturer's installation and maintenance manual for motor bearing lubrication information.

BEARING LUBRICATION INTERVAL

**Duct, Industrial Duct, Tubeaxial, Vaneaxial, Vaneaxial Adj. Pitch and Inline Centrifugal Fans
(months)**

Shaft	RPM									
	1-500	501-1000	1001-1500	1501-2000	2001-2500	2501-3000	3001-3500	3501-4000	4001-4500	4501-5000
1	6	6	5-6	5-6	4-6	4-6	3-4	3-4	2	2
1 3/16 thru 1 7/16	6	6	5-6	4-6	4-6	3-5	2-4	2-4	1-2	1
1 11/16 thru 1 15/16	6	6	4-6	4-6	2-4	2-4	2	1-2		
2 3/16	6	5-6	4-6	3-4	2-4					
2 7/16	6	4-6	4-6	3-4						
2 11/16 & 2 15/16	5-6	4-6	2-4	2						
3 7/16 thru 4 3/16	4-6	3-5	2-4	1						

Ball bearings & Split Pillowblock Spherical Roller Bearings

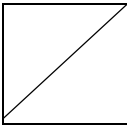

Non-Split Pillowblock Spherical Roller Bearings

NOTE:

1. These are general recommendations only; specific manufacturer's recommendations may vary slightly.
2. Assumes clean environment, -20°F to 120°F
 - a. Consult The New York Blower Company for operation below -20°F ambient.
 - b. Ambient temperatures greater than 120°F. will shorten bearing life. (Duct Fan and Industrial Duct Fan are available with high operating temperatures.
 - c. Under extremely dirty conditions, lubricate more frequently.
3. Assumes horizontal mounting configuration. For vertically mounted applications, lubricate twice as frequently.

BEARING LUBRICATION INTERVAL – Fixed Pitch Vaneaxial Fan (months)

Horizontal Orientation

SHAFT DIAMETER	FLANGE BEARING TYPES	RECOMMENDED GREASE AMOUNTS (OUNCES)	FAN SPEED RANGE (RPM)								
			1-500	501-1000	1001-1500	1501-2000	2001-2500	2501-3000	3001-3500	3501-4000	4000-4500
1 3/16	BALL	0.50	17	11	9	7	6	5 1/2	5	4 1/2	4
1 7/16	SPHERICAL ROLLER	0.50	4	2 1/2	1 3/4	1 1/4	1	1/2	1/2	1/4	1/4
1 11/16	SPHERICAL ROLLER	0.50	4	2 1/2	1 1/2	1	3/4	1/2	1/4	1/4	1/4
1 15/16	SPHERICAL ROLLER	0.50	4	2 1/2	1 1/2	1	3/4	1/4	1/4	1/4	1/4
2 3/16	SPHERICAL ROLLER	0.50	3 3/4	2 1/4	1 1/4	3/4	1/2	1/4	1/4	1/4	
2 7/16	SPHERICAL ROLLER	0.75	3 1/2	2	1	3/4	1/4	1/4	1/4		
2 11/16	SPHERICAL ROLLER	1.25	3 1/2	2	1	1/2	1/4	1/4			

Vertical Orientation

SHAFT DIAMETER	FLANGE BEARING TYPES	RECOMMENDED GREASE AMOUNTS (OUNCES)	FAN SPEED RANGE (RPM)								
			1-500	501-1000	1001-1500	1501-2000	2001-2500	2501-3000	3001-3500	3501-4000	4000-4500
1 3/16	BALL	0.50	8 1/2	5 1/2	4 1/2	3 1/2	3	2 3/4	2 1/2	2 1/4	2
1 7/16	SPHERICAL ROLLER	0.50	2	1 3/4	3/4	3/4	1/2	1/4	1/4	1/8	1/8
1 11/16	SPHERICAL ROLLER	0.50	2	1 1/4	3/4	1/2	1/2	1/4	1/8	1/8	1/8
1 15/16	SPHERICAL ROLLER	0.50	2	1 1/4	3/4	1/2	1/2	1/8	1/8	1/8	1/8
2 3/16	SPHERICAL ROLLER	0.50	1 3/4	1	3/4	1/4	1/4	1/8	1/8	1/8	
2 7/16	SPHERICAL ROLLER	0.75	1 3/4	1	1/2	1/4	1/8	1/8	1/8		
2 11/16	SPHERICAL ROLLER	1.25	1 3/4	1	1/2	1/4	1/8	1/8			

NOTE:

1. These are general recommendations only; specific manufacturer's recommendations may vary slightly.
2. Assumes clean environment, -20°F to 120°F
 - a. Consult The New York Blower Company for operation below -20°F ambient.
 - b. Ambient temperatures greater than 120°F. will shorten bearing life.
 - c. Under extremely dirty conditions, lubricate more frequently.

BLADE ANGLE ADJUSTMENT – Adjustable Pitch Vaneaxial Fan

The fan wheel's blade angles are pre-set at the factory to provide the operating performance at the specified flow and pressure. Prior to start-up, it is recommended to inspect each blade's angle (position). If the blade angles need to be changed, do not disassemble the wheel since incorrect reassembly could alter the wheel balance and may affect wheel positioning.

If a blade angle adjustment is required, the following procedure should be used (**read the entire set of instructions prior to proceeding**):

1. **Prior to changing the blade angle, check the performance data/motor amp draw to prevent overloading the motor.**
2. Follow all safety protocols and confirm electrical power has been locked/tagged out. Bump the starter to confirm electric power has been disconnected.
3. Unbolt and remove wheel access door from fan housing. (All blade adjustments will be made through the wheel access door.)
4. Adjust one blade at a time to prevent potential balance and alignment issues.
5. Loosen, but **DO NOT** remove the two socket head cap screws holding each blade in position [*Note: removing both fasteners will dislodge the internal blade capture plate. If dislodged, user will need to access the wheel from the inlet side of the fan, remove the spinner (hub cover) and reinstall the capture plate prior to proceeding*].
6. Rotate blade to the required blade angle (see Figure 4). Use the air-handling side of the blade to align blade to hub mark indicators. The marks indicate blade position between 15° to 55° (in 5° increments). Adjust blade between hub marks for 2.5° settings.
7. Torque blade fasteners per Table I. *It is critical to take care in performing this step correctly.*
8. Adjust each subsequent blade to the same angle, repeating steps 4 through 7 above.
9. Once all blade angle adjustments are complete, secure the wheel access door prior to operating fan. It is recommended to re-check both fan balance and motor amperage draw after the blade adjustments have been made to ensure that the fan is operating within the motor nameplate requirements.

Figure 4: Blade shown at 55°

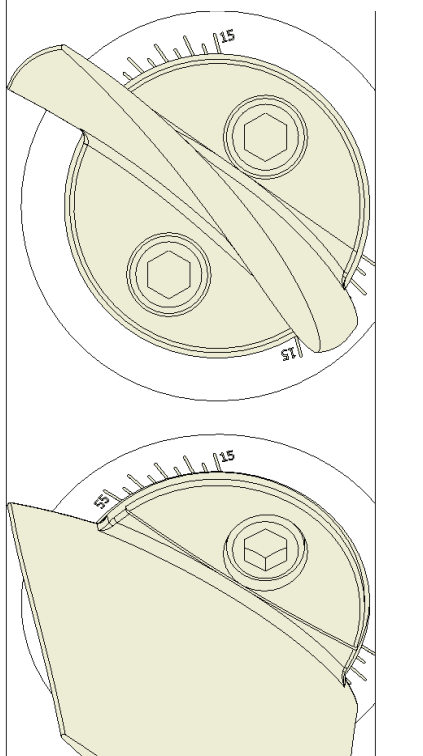

Table I:
Blade Hardware Torques

Size	Torque [lbf-ft] 0.60 hub ratio	Torque [lbf-ft] 0.45 hub ratio
21	29	–
24	29	–
27	67	–
29	135	–
32	135	70
36	135	135
38	135	135
42	135	135
48	236	135
54	236	135
60	570	200

COMMON FAN PROBLEMS

Excessive Vibration

A common complaint regarding industrial fans is "excessive vibration". **nyb** is careful to ensure that each unit is precisely balanced prior to shipment; however, there are many other causes of vibration including:

1. Loose mounting bolts, setscrews, bearings or couplings.
2. Misalignment or excessive wear of couplings or bearings
3. Misaligned or unbalanced motor.
4. Bent shaft due to mishandling or material impact.
5. Accumulation of foreign material on the wheel.
6. Excessive wear or erosion of the wheel.
7. Excessive system pressure or restriction of airflow due to closed dampers.
8. Inadequate structural support, mounting procedures or materials.
9. Externally transmitted vibration.

Inadequate Performance

1. Incorrect testing procedures or calculations.
2. Fan running too slowly.
3. Fan wheel rotating in wrong direction or installed backwards on shaft.
4. Wheel not properly centered relative to inlet cone.
5. Damaged or incorrectly installed cut off sheet or diverter.
6. Poor system design, closed dampers, air leaks, clogged filters, or coils.
7. Obstructions or sharp elbows near inlets.
8. Sharp deflection of airstream at fan outlet.

Excessive Noise

1. Fan operating near "stall" due to incorrect system design or installation.
2. Vibration originating elsewhere in the system.
3. System resonance or pulsation.
4. Improper location or orientation of fan intake and discharge.
5. Inadequate or faulty design of supporting structures.
6. Nearby sound reflecting surfaces.
7. Loose accessories or components.
8. Loose drive belts.
9. Worn bearings.

Premature Component Failure

1. Prolonged or major vibration.
2. Inadequate or improper maintenance.
3. Abrasive or corrosive elements in the airstream or surrounding environment.
4. Misalignment or physical damage to rotating components or bearings.
5. Bearing failure from incorrect or contaminated lubricant or grounding through the bearings while arc welding.
6. Excessive fan speed.
7. Extreme ambient or airstream temperatures.
8. Improper belt tension.
9. Improper tightening of wheel setscrews.

REPLACEMENT PARTS

It is recommended that only factory-supplied replacement parts be used. **nyb** fan parts are built to be fully compatible with the original fan, using specific alloys and tolerances. These parts carry a standard **nyb** warranty.

When ordering replacement parts, specify the part name, **nyb** shop and control number, fan group, fan size, type, rotation (viewed from drive end), arrangement and bearing size or bore. Most of this information is on the metal nameplate attached to the fan base.

For assistance in selecting replacement parts, contact your local **nyb** representative or visit: <http://www.nyb.com>.

Example: Part required: Wheel

Shop/control number: 2017-10106-1

Fan description: Size 66 Tubular AcoustaFoil

Rotation: Clockwise

Arrangement: 9M

Suggested replacement parts include:

Wheel

Shaft

Bearings

Shaft Seal

Sheaves

V-Belts

Component parts: Damper
Motor

LIMITED PRODUCT WARRANTY

All products are warranted by **nyb** to be free from defects in materials and workmanship for a period of one (1) year after shipment from its plant, provided buyer demonstrates to satisfaction of **nyb** that the product was properly installed and maintained in accordance with **nyb's** instructions and recommendations and that it was used under normal operating conditions.

This warranty is limited to the replacing and/or repairing by **nyb** of any part or parts which have been returned to **nyb** with **nyb's** written authorization and which in **nyb's** opinion are defective. Parts not manufactured by **nyb** but installed by **nyb** in equipment sold to the buyer shall carry the original manufacturer's warranty only. All transportation charges and any and all sales and use taxes, duties, imports or excises for such part or parts shall be paid for by the buyer. **nyb** shall have the sole right to determine whether defective parts shall be repaired or replaced.

This warranty does not cover any customer labor charges for replacement of parts, adjustments or repairs, or any other work unless such charges shall be assumed or authorized in advance, in writing, by **nyb**.

This warranty does not cover any product which, in the judgment of **nyb**, has been subject to misuse or neglect, or which has been repaired or altered outside **nyb's** plant in any way which may have impaired its safety, operation or efficiency, or any product which has been subject to accident.

This warranty shall be null and void if any part not manufactured or supplied by **nyb** for use in any of its products shall have been substituted and used in place of a part manufactured or supplied by **nyb** for such use.

There are no warranties, other than those appearing on the acknowledgement form **INCLUDING NO WARRANTY OF MERCHANTABILITY OR FITNESS FOR A PARTICULAR PURPOSE**, given in connection with the sale of the goods sold hereunder. The buyer agrees that his sole and exclusive remedy, and the limit of **nyb's** liability for loss from any cause whatsoever, shall be the purchase price of the goods sold hereunder for which a claim is made.

AXIAL FANS AIR DIRECTION

AXIAL FAN AIRFLOW DIRECTION

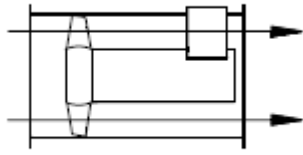

TUBEAXIAL, VANEAXIAL,
VXFP, VXAP

AXIAL FAN AIRFLOW DIRECTION

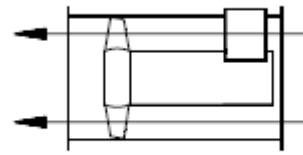

DUCT FAN,
INDUSTRIAL DUCT FAN

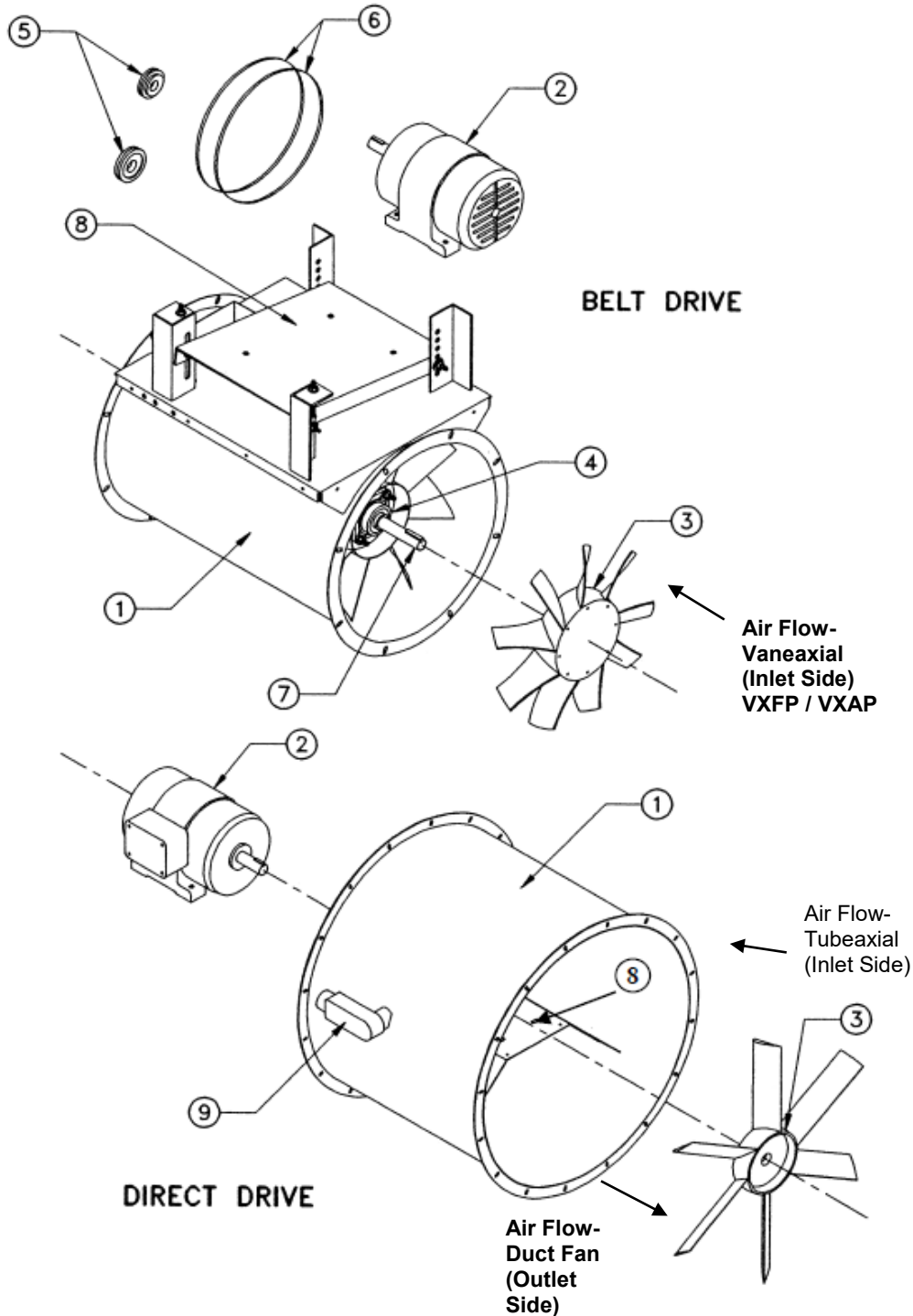

Parts List

1. Housing
2. Motor
3. Wheel
4. Bearings
5. Sheaves
6. Belts
7. Shaft
8. Motor Platform
9. External Conduit Box

For assistance in selecting replacement parts, contact your local **nyb** representative or visit: <http://www.nyb.com>.

TUBULAR CENTRIFUGAL FANS
WHEEL ROTATION AS VIEWED FROM DISCHARGE END

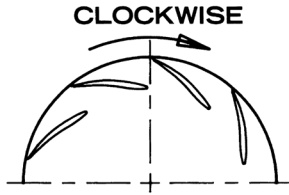

ARROW INDICATES CORRECT ROTATION

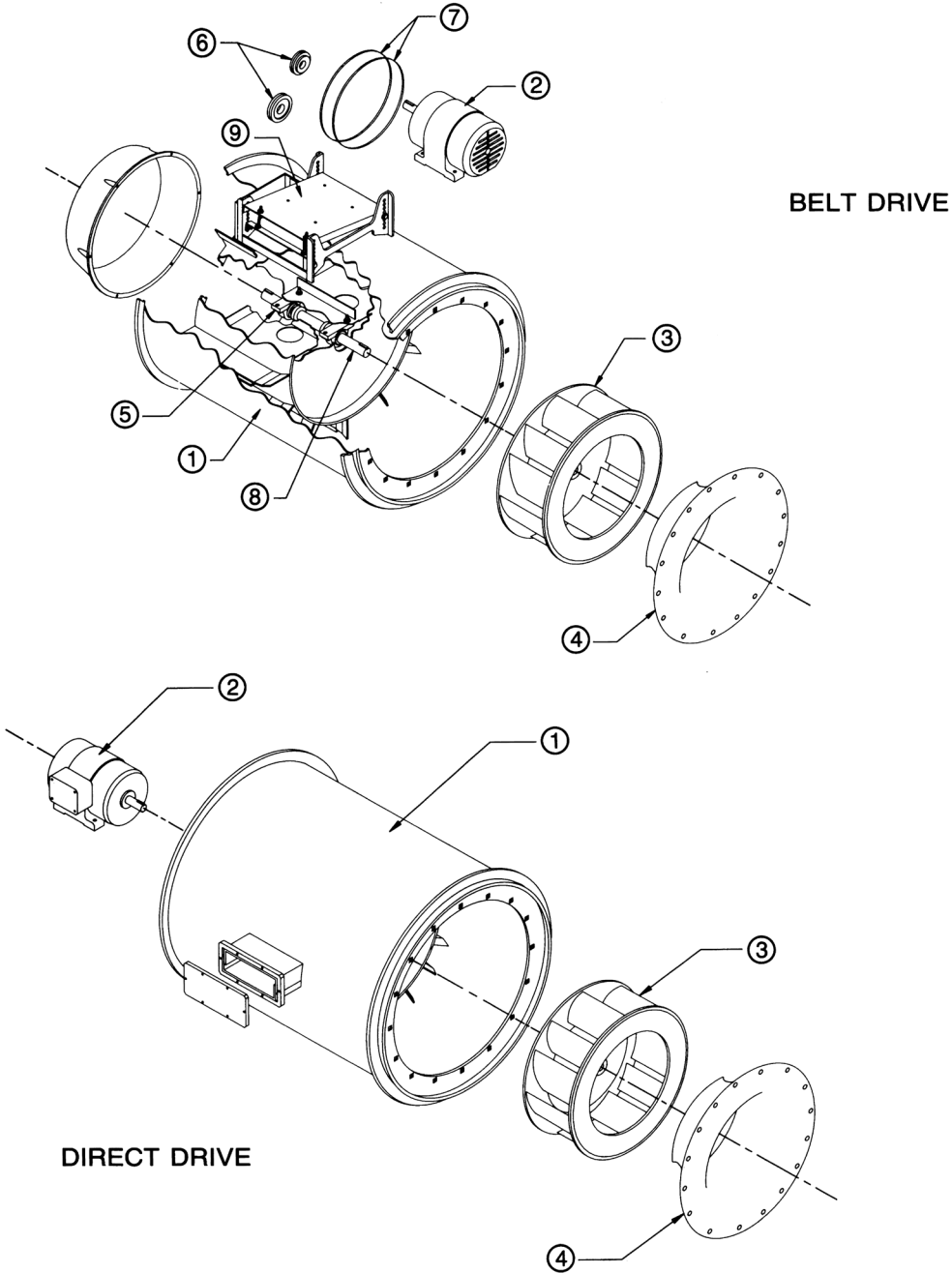

Parts List

1. Housing
2. Motor
3. Wheel*
4. Inlet Cone with Diverters*
5. Bearings
6. Sheaves
7. Belts
8. Shaft
9. Motor Platform

* Orders for parts must specify rotation.

For assistance in selecting replacement parts, contact your local **nyb** representative or visit: <http://www.nyb.com>.