

# CUBE ARRAY PLENUM FANS

BULLETIN 202  
APRIL, 2018

- Capacities to 21,000 CFM
- Reliable Uniform Airflow
- Static pressures to 14" WG
- Direct-Drive



THE NEW YORK BLOWER COMPANY  
7660 Quincy Street  
Willowbrook, IL 60527-5530

Visit us on the Web: <http://www.nyb.com>  
Phone: (800) 208-7918 Email: [nyb@nyb.com](mailto:nyb@nyb.com)

Size 22 Single CA Plenum Fan



Size 22, CA Plenum Fan Array

# CA PLENUM FANS

The New York Blower Company's CA (Cube Array) Plenum Fans are designed specifically for fan array applications found in industrial and commercial air-handling systems. Designed to provide the highest pressure capabilities in the industry, the CA Plenum Fans can be used as a single, stand-alone fan, or in parallel as an array to provide a superior level of air-flow performance and quiet operation. Ideal for retrofits or new system applications.

## DESIGN FEATURES

- Capacities to 21,000 CFM as a stand-alone fan.
- Pressures to 14" WG.
- Temperatures to 120°F.
- Direct Drive CA Plenum Fans are constructed with High Efficiency Airfoil Wheels.
  - Available in six sizes: 13" - 22"
- Custom blade widths-
  - Customized blade widths to achieve optimized wheel performance and peak efficiencies. Available in 1% increments.
    - Size 13: 42% - 100%
    - Size 15: 38% - 100%
    - Size 16: 32% - 100%
    - Sizes 18-22: 30% - 100%
- Reliable Uniform Airflow
- Modular Flexibility - Combine to create an array for redundancy capability
- Low Maintenance - Cost Effective - No Belts, No Sheaves, No Bearings
- Designed and tested for use with variable frequency drives to minimize natural frequencies through the operating range.

## FAN TO SIZE AND DRAWINGS ON DEMAND

Fan to Size online allows customers to select fans without the need to download software on their computers or tablets. Fans can be selected by product categories, types or applications. Additionally, drawings are generated to supplement fan selections.

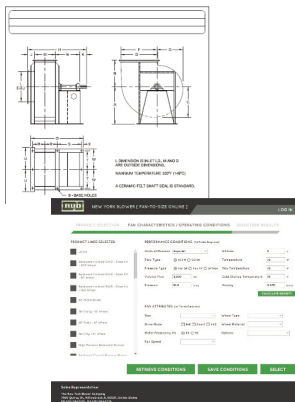

### FAN TO SIZE SELECTION BENEFITS

- Compare multiple product lines.
- Metric or English units.
- Add silencers.
- Add accessories.
- Save data for future use.
- Calculate density based on rarefaction, compression, and molecular weight.

### DRAWINGS ON DEMAND BENEFITS

- Generate drawing package specifically tailored to the user's application requirements.
- Fan-performance curves.
- Select fan's rotation, discharge position, motor frame size and u-base.
- Add accessories (dampers, silencers, stack hoods, curb caps)
- Installation and Maintenance Manuals.

# CONSTRUCTION FEATURES

1. The CA Plenum Fans are constructed of welded high strength aluminum frames.
2. Aluminum exterior provides corrosion resistance & reduced weight.
3. Integral welded lifting points.
4. 2" insulated panels with galvanized steel perforated liner for quiet operation.
5. Airfoil wheels constructed of aluminum with welded extruded blades.
6. NEMA Motors (available with shaft grounding).
7. Wheels are dynamically balanced to G6.3 and ANSI S2.19 specifications. Each fan is balanced and recorded to meet BV-4 AMCA/ANSI Standard 204-05 (Balance Quality and Vibration Levels for Fans) at the specified operating speed.
8. Internal rubber-in-shear isolators selected for each fan/motor weight for optimal performance.
9. Aluminum cone provided as standard.

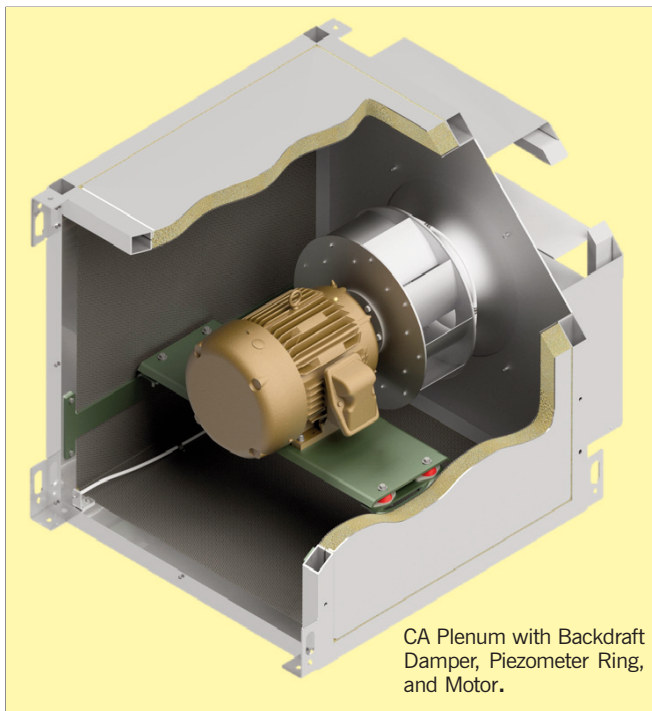

CA Plenum with Backdraft Damper, Piezometer Ring, and Motor.

# ACCESSORIES AND MODIFICATIONS

## 1. AIR TRACKER 6000

An accurate, cost effective system for measuring fan air flow with no impact on fan performance. Integral cone-mounted piezometer ring installed and piped at the factory. Optional micro-processor based LED display available. Can be integrated with building management systems.



## 2. BACKDRAFT DAMPERS

Heavy duty backdraft dampers will automatically close when power is lost and will prevent backflow of air through the fan.

## 3. MOTORS WITH SHAFT GROUNDING

Shaft grounding available with Aegis shaft grounding rings or shaft grounding brushes available to protect motors against voltage spikes that can be associated with fans operating on variable frequency drives.

## 4. INLET GUARD

Heavy-gauge wire inlet guard used to protect personnel and debris from entering the fan inlet.

## 5. OUTLET GUARD

Heavy-gauge safety screen mounted on discharge side of fan to protect personnel and debris from reaching inside of cube and the fan's moving parts.

## 6. NARROW-WIDTH CONSTRUCTION

Versatile custom wheel blade width options available to provide optimum flexibility and maximize efficiency to meet specific application requirements. Available in 1% increments from a range of blade widths (See page 2 for more details). *Optimum blade widths can be calculated automatically with the new york blower's selection program - Fan to Size found on nyb's website at [www.nyb.com](http://www.nyb.com).*

## SAFETY EQUIPMENT

Safety accessories are available from nyb, but selection of the appropriate devices is the responsibility of the system-designer who is familiar with the particular installation, or application, and can provide for guards for all exposed moving parts as well as protection from access to high-velocity airstreams. Neither nyb nor its sales representatives is in a position to make such a determination. Users and/or installers should read "Recommended Safety Practices for Air Moving Devices" as published by the Air Movement and Control Association, Arlington Heights, Illinois.

# CA PLENUM CAPACITY INFORMATION

## SIZE 13

		1"SP		2"SP		3"SP		4"SP		5"SP		6"SP		7"SP		8"SP		9"SP		10"SP		11"SP	
CFM	OV	CFM	BHP	CFM	BHP	CFM	BHP	CFM	BHP	CFM	BHP	CFM	BHP	CFM	BHP	CFM	BHP	CFM	BHP	CFM	BHP	CFM	BHP
1000	230	1420	0.25	-	-	-	-	-	-	-	-	-	-	-	-	-	-	-	-	-	-	-	-
1500	346	1708	0.40	2046	0.25	2366	1.12	-	-	-	-	-	-	-	-	-	-	-	-	-	-	-	-
2000	461	2040	0.64	2335	0.44	2592	1.50	2839	1.98	3074	2.47	3320	3.02	-	-	-	-	-	-	-	-	-	-
2500	576	2380	0.97	2668	0.70	2894	1.99	3100	2.53	3302	3.12	3497	3.71	3690	4.33	3878	4.95	4076	5.64	4283	6.40	-	-
3000	691	2728	1.39	3005	1.08	3225	2.61	3417	3.23	3590	3.87	3762	4.55	3930	5.25	4096	5.97	4258	6.70	-	-	-	-
3500	806	3090	1.94	3340	1.58	3560	3.40	3752	4.11	3916	4.81	4072	5.55	4221	6.31	-	-	-	-	-	-	-	-
4000	922	3466	2.65	3686	2.25	3898	4.33	4082	5.13	4250	5.94	-	-	-	-	-	-	-	-	-	-	-	-
4500	1037	3848	3.53	4042	3.09	4236	5.40	-	-	-	-	-	-	-	-	-	-	-	-	-	-	-	-
5000	1152	4236	4.61	-	-	-	-	-	-	-	-	-	-	-	-	-	-	-	-	-	-	-	-

## SIZE 15

		1"SP		2"SP		3"SP		4"SP		5"SP		6"SP		7"SP		8"SP		9"SP		10"SP		11"SP	
CFM	OV	CFM	BHP	CFM	BHP	CFM	BHP	CFM	BHP	CFM	BHP	CFM	BHP	CFM	BHP	CFM	BHP	CFM	BHP	CFM	BHP	CFM	BHP
1000	207	1220	0.25	-	-	-	-	-	-	-	-	-	-	-	-	-	-	-	-	-	-	-	-
1500	311	1376	0.38	1737	0.75	-	-	-	-	-	-	-	-	-	-	-	-	-	-	-	-	-	-
2000	415	1611	0.56	1898	1.00	2166	1.50	2441	2.03	-	-	-	-	-	-	-	-	-	-	-	-	-	-
2500	518	1852	0.81	2115	1.31	2346	1.99	2567	2.49	2774	3.09	2990	3.76	3296	5.19	3472	5.96	3658	6.83	-	-	-	-
3000	622	2100	1.13	2360	1.74	2567	2.61	2753	3.02	2940	3.74	3120	4.46	3462	6.10	3616	6.95	3766	7.79	-	-	-	-
3500	726	2350	1.53	2602	2.25	2804	3.40	2980	3.69	3140	4.44	3302	5.26	3656	7.07	3796	8.00	-	-	-	-	-	-
4000	829	2612	2.03	2848	2.86	3050	4.33	3220	4.49	3371	5.31	3516	6.18	-	-	-	-	-	-	-	-	-	-
4500	933	2880	2.64	3096	3.58	3291	5.40	3462	5.41	3612	6.32	3748	7.24	-	-	-	-	-	-	-	-	-	-
5000	1037	3154	3.38	3351	4.42	3536	5.46	3704	6.47	-	-	-	-	-	-	-	-	-	-	-	-	-	-
5500	1140	3432	4.25	3608	5.38	3786	6.55	-	-	-	-	-	-	-	-	-	-	-	-	-	-	-	-
6000	1244	3714	5.29	-	-	-	-	-	-	-	-	-	-	-	-	-	-	-	-	-	-	-	-

## SIZE 16

		1"SP		2"SP		3"SP		4"SP		5"SP		6"SP		7"SP		8"SP		9"SP		10"SP		11"SP	
CFM	OV	CFM	BHP	CFM	BHP	CFM	BHP	CFM	BHP	CFM	BHP	CFM	BHP	CFM	BHP	CFM	BHP	CFM	BHP	CFM	BHP	CFM	BHP
1500	219	1119	0.41	-	-	-	-	-	-	-	-	-	-	-	-	-	-	-	-	-	-	-	-
2000	293	1205	0.53	1574	1.10	-	-	-	-	-	-	-	-	-	-	-	-	-	-	-	-	-	-
2500	366	1345	0.71	1636	1.33	1929	2.05	-	-	-	-	-	-	-	-	-	-	-	-	-	-	-	-
3000	439	1496	0.94	1752	1.62	1994	2.39	2240	3.25	-	-	-	-	-	-	-	-	-	-	-	-	-	-
3500	512	1660	1.22	1894	1.99	2100	2.81	2306	3.71	2521	4.71	2728	5.76	-	-	-	-	-	-	-	-	-	-
4000	585	1834	1.58	2040	2.41	2235	3.32	2415	4.28	2596	5.30	2779	6.39	2965	7.57	3145	8.79	-	-	-	-	-	-
4500	658	2015	2.03	2195	2.91	2380	3.90	2547	4.93	2708	6.03	2865	7.15	3030	8.37	3196	9.65	3360	11.0	3520	12.4	-	-
5000	731	2195	2.55	2364	3.53	2532	4.59	2693	5.71	2839	6.84	2985	8.06	3125	9.28	3274	10.6	3422	12.0	3570	13.4	-	-
5500	804	2380	3.19	2541	4.26	2688	5.35	2839	6.54	2985	7.80	3116	9.04	3245	10.3	3376	11.7	3508	13.1	3642	14.6	3776	16.1
6000	878	2567	3.92	2718	5.07	2854	6.25	2994	7.52	3130	8.82	3260	10.2	3382	11.5	3502	13.0	3622	14.4	3740	15.9	3864	17.5
6500	951	2759	4.81	2896	5.99	3025	7.25	3154	8.60	3280	9.96	3408	11.4	3530	12.9	3642	14.4	3752	15.9	3862	17.5	-	-
7000	1024	2945	5.75	3080	7.08	3205	8.44	3320	9.80	3437	11.2	3560	12.8	3676	14.3	3786	15.9	3893	17.5	-	-	-	-
7500	1097	3140	6.90	3265	8.30	3382	9.71	3492	11.2	3602	12.7	3714	14.3	3826	15.9	3936	17.6	-	-	-	-	-	-
8000	1170	3331	8.15	3448	9.62	3565	11.2	3670	12.7	3772	14.3	3873	15.9	-	-	-	-	-	-	-	-	-	-
8500	1243	3526	9.59	3636	11.2	3744	12.7	3848	14.4	3946	16.0	-	-	-	-	-	-	-	-	-	-	-	-
9000	1316	3720	11.2	3826	12.9	3930	14.5	-	-	-	-	-	-	-	-	-	-	-	-	-	-	-	-
9500	1389	3916	13.0	-	-	-	-	-	-	-	-	-	-	-	-	-	-	-	-	-	-	-	-

Performance shown is installation Type A: Free Inlet, Free Outlet. Performance ratings do not include the effects of appurtenances in the airstream.

# CA PLENUM CAPACITY INFORMATION

## SIZE 18

CFM	OV	1"SP		2"SP		3"SP		4"SP		5"SP		6"SP		7"SP		8"SP		9"SP		10"SP		11"SP	
		CFM	BHP	CFM	BHP	CFM	BHP	CFM	BHP	CFM	BHP	CFM	BHP	CFM	BHP	CFM	BHP	CFM	BHP	CFM	BHP	CFM	BHP
2000	264	1028	0.54	1405	1.17	-	-	-	-	-	-	-	-	-	-	-	-	-	-	-	-	-	-
3000	397	1205	0.85	1470	1.59	1742	2.47	1994	3.46	-	-	-	-	-	-	-	-	-	-	-	-	-	-
4000	529	1430	1.32	1651	2.21	1848	3.18	2055	4.28	2255	5.44	2452	6.71	2638	8.03	2814	9.43	-	-	-	-	-	-
5000	661	1686	2.02	1872	3.07	2044	4.18	2204	5.37	2364	6.64	2526	7.99	2688	9.41	2850	10.9	3005	12.47	3160	14.1	3306	15.8
6000	793	1954	3.00	2110	4.18	2264	5.46	2410	6.80	2541	8.15	2673	9.60	2808	11.1	2945	12.8	3080	14.4	3216	16.1	3351	17.9
7000	926	2226	4.28	2366	5.61	2496	7.02	2627	8.50	2759	10.1	2876	11.7	2990	13.3	3100	15.0	3216	16.8	3331	18.6	3448	20.5
8000	1058	2506	5.94	2632	7.44	2748	8.98	2859	10.6	2976	12.3	3094	14.1	3200	15.9	3302	17.7	3402	19.6	3502	21.5	3598	23.4
9000	1190	2788	8.01	2905	9.73	3010	11.4	3114	13.2	3214	15.0	3316	16.9	3417	18.8	3520	20.9	3612	22.9	-	-	-	-
10000	1322	3074	10.6	3176	12.4	3280	14.3	3371	16.2	3466	18.2	3554	20.2	3647	22.3	-	-	-	-	-	-	-	-
11000	1455	3360	13.6	3457	15.7	3550	17.8	3638	19.8	-	-	-	-	-	-	-	-	-	-	-	-	-	-
12000	1587	3647	17.2	-	-	-	-	-	-	-	-	-	-	-	-	-	-	-	-	-	-	-	-

## SIZE 20

CFM	OV	1"SP		2"SP		3"SP		4"SP		5"SP		6"SP		7"SP		8"SP		9"SP		10"SP		11"SP	
		CFM	BHP	CFM	BHP	CFM	BHP	CFM	BHP	CFM	BHP	CFM	BHP	CFM	BHP	CFM	BHP	CFM	BHP	CFM	BHP	CFM	BHP
2000	240	907	0.56	-	-	-	-	-	-	-	-	-	-	-	-	-	-	-	-	-	-	-	-
3000	360	993	0.80	1290	1.64	1565	2.65	-	-	-	-	-	-	-	-	-	-	-	-	-	-	-	-
4000	480	1150	1.18	1374	2.13	1600	3.24	1818	4.47	2020	5.79	-	-	-	-	-	-	-	-	-	-	-	-
5000	600	1325	1.70	1520	2.80	1697	4.01	1874	5.32	2055	6.78	2230	8.33	2395	9.93	2552	11.6	-	-	-	-	-	-
6000	719	1514	2.40	1682	3.64	1843	5.01	1989	6.44	2135	7.96	2284	9.59	2435	11.3	2582	13.2	2724	15.0	2865	17.0	2996	19.0
7000	839	1712	3.32	1858	4.70	2004	6.22	2135	7.76	2264	9.45	2386	11.1	2516	13.0	2642	14.9	2774	16.9	2900	19.0	3025	21.1
8000	959	1914	4.49	2046	6.02	2175	7.70	2300	9.43	2420	11.3	2530	13.1	2638	15.0	2748	17.0	2859	19.1	2970	21.2	3085	25.5
9000	1079	2120	5.94	2244	7.67	2355	9.43	2466	11.3	2582	13.3	2688	15.3	2788	17.4	2885	19.5	2980	21.7	3080	24.0	3176	26.2
10000	1199	2330	7.73	2441	9.58	2547	11.6	2647	13.6	2748	15.7	2850	17.9	2945	20.0	3040	22.4	3130	24.7	3216	27.1	3302	29.4
11000	1319	2541	9.87	2647	12.0	2744	14.0	2834	16.1	2925	18.4	3020	20.8	3110	23.1	3200	25.5	3285	28.0	3371	30.6	-	-
12000	1439	2753	12.4	2850	14.6	2945	17.0	3030	19.2	3114	21.6	3196	24.0	3280	26.5	3366	29.2	-	-	-	-	-	-
13000	1559	2965	15.3	3056	17.7	3145	20.2	3225	22.6	3306	25.2	3382	27.8	-	-	-	-	-	-	-	-	-	-
14000	1679	3185	18.8	3265	21.3	3346	23.9	-	-	-	-	-	-	-	-	-	-	-	-	-	-	-	-

## SIZE 22

CFM	OV	1"SP		2"SP		3"SP		4"SP		5"SP		6"SP		7"SP		8"SP		9"SP		10"SP		11"SP	
		CFM	BHP	CFM	BHP	CFM	BHP	CFM	BHP	CFM	BHP	CFM	BHP	CFM	BHP	CFM	BHP	CFM	BHP	CFM	BHP	CFM	BHP
3000	284	841	0.78	-	-	-	-	-	-	-	-	-	-	-	-	-	-	-	-	-	-	-	-
4000	379	938	1.11	-	-	-	-	-	-	-	-	-	-	-	-	-	-	-	-	-	-	-	-
5000	473	1074	1.57	1250	2.66	1456	3.96	-	-	-	-	-	-	-	-	-	-	-	-	-	-	-	-
6000	568	1216	2.15	1374	3.45	1516	4.74	1682	6.24	-	-	-	-	-	-	-	-	-	-	-	-	-	-
7000	663	1360	2.85	1510	4.38	1636	5.88	1762	7.45	1894	9.07	2060	11.2	-	-	-	-	-	-	-	-	-	-
8000	757	1505	3.71	1651	5.48	1772	7.23	1878	8.91	1989	10.7	2100	12.5	2230	14.6	-	-	-	-	-	-	-	-
9000	852	1656	4.78	1797	6.81	1909	8.71	2015	10.7	2110	12.6	2204	14.6	2300	16.5	2406	18.7	2526	21.1	2658	23.9	-	-
10000	947	1808	6.04	1940	8.27	2055	10.5	2150	12.6	2240	14.7	2330	17.0	2415	19.1	2501	21.3	2592	23.6	2688	26.0	2794	28.7
11000	1041	1960	7.51	2084	9.93	2195	12.4	2295	14.9	2380	17.2	2461	19.5	2541	21.9	2618	24.3	2698	26.7	2779	29.2	2859	31.7
12000	1136	2115	9.24	2230	11.8	2340	14.6	2435	17.3	2521	19.9	2598	22.4	2673	24.9	2748	27.6	2819	30.1	2890	32.8	2965	35.5
13000	1231	2275	11.4	2380	14.1	2486	17.1	2578	19.9	2664	22.8	2742	25.7	2814	28.4	2885	31.2	2950	33.9	3016	36.7	3085	39.7
14000	1325	2435	13.7	2532	16.6	2632	19.8	2722	22.9	2808	26.1	2885	29.2	2954	32.1	3025	35.2	3085	38.0	-	-	-	-
15000	1420	2596	16.5	2688	19.6	2779	22.8	2865	26.1	2950	29.6	3025	32.9	3096	36.1	-	-	-	-	-	-	-	-
16000	1515	2759	19.6	2844	22.8	2925	26.1	3014	29.8	3094	33.4	-	-	-	-	-	-	-	-	-	-	-	-
17000	1609	2920	23.1	3000	26.4	3080	30.0	-	-	-	-	-	-	-	-	-	-	-	-	-	-	-	-
18000	1704	3080	26.9	-	-	-	-	-	-	-	-	-	-	-	-	-	-	-	-	-	-	-	-

Performance shown is installation Type A: Free Inlet, Free Outlet. Performance ratings do not include the effects of appurtenances in the airstream.

# DIRECT-DRIVE PLENUM FANS WITH VFD CONTROL

With the development of less costly and more reliable variable frequency drives (VFDs), and greater acceptance in the industry, direct-drive plenum fans with VFD controls are often the design choice for single fans or fan arrays. VFDs allow operation at non-synchronous motor speeds permitting fan selection at exact points of system flow and pressure. However, in some “turn-down” selections, the motor’s synchronous speed may exceed the fan’s maximum safe speed. In these cases, care must be taken to ensure that the fan does not operate in the full by-pass mode. The figure provides maximum safe speeds of full width fans. Maximum safe speeds increase with the selection of narrow-width wheels for reduced flow or higher pressure applications. Nyb’s selection software (Fan to Size) automatically calculates the final maximum safe speed at the selected width and operating temperature. Using Fan to Size to calculate and plot fan performance, the system designer can often improve fan efficiency, motor VFD speed requirements, and select the fan at the optimum point on the pressure curve.

## FAN CONTROL WITH VARIABLE FREQUENCY DRIVES

Variable frequency drives (VFDs) are becoming more common as fans are increasingly being specified and selected for direct-drive applications. The characteristics of each component must be taken into consideration when designing a fan system that incorporates a direct-drive motor accompanied by a VFD. For instance, as outlined in the below set of equations, fan horsepower is influenced by the speed of the fan cubed, whereas torque is influenced by the speed of the fan squared:

$$BHP_{NEW} = (RPM_{NEW} / RPM_{ORIGINAL})^3 \times BHP_{ORIGINAL}$$

$$T_{NEW} = (RPM_{NEW} / RPM_{ORIGINAL})^2 \times T_{ORIGINAL}$$

However, the horsepower output of the motor is influenced directly with respect to motor speed, but remains constant when it reaches the design speed:

$$BHP_{MOTOR} = (T \times RPM) / 5250, \text{ if } RPM \leq RPM_{RATED, MOTOR}$$

$$BHP_{MAX, MOTOR} = (T_{MAX} \times RPM_{RATED, MOTOR}) / 5250,$$

if  $RPM > RPM_{RATED, MOTOR}$

Conversely, the torque output of the motor is constant until the design speed is reached; thereafter the torque is reduced in direct proportion relative to motor speed:

$$T_{ACTUAL} = T_{RATED, MOTOR}, \text{ if } RPM_{ACTUAL} \leq RPM_{RATED, MOTOR}$$

$$T_{ACTUAL} = (5250 \times BHP_{MAX, ELEC. MOTOR}) / RPM_{ACTUAL},$$

if  $RPM_{ACTUAL} > RPM_{RATED, MOTOR}$

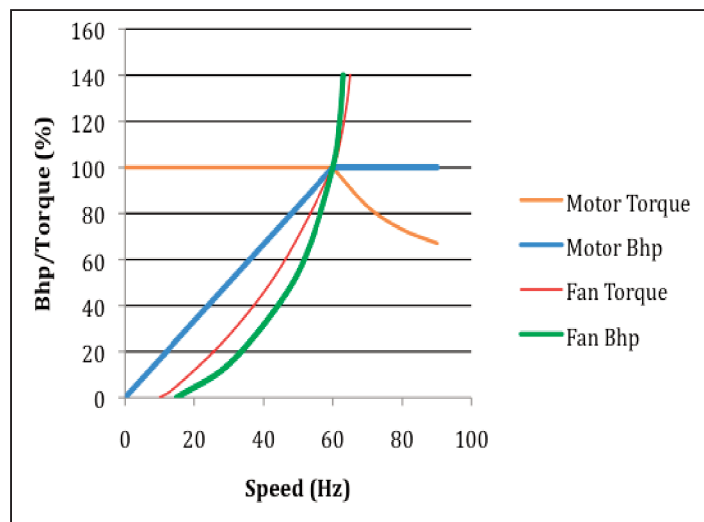

This figure illustrates the relationship between the fan’s horsepower and torque requirements compared to the operational horsepower and torque limitations of the motor. The motor must be able to meet the performance requirements of the fan throughout its performance range.

Specific limitations apply to the individual components of these systems. Most importantly, the fans are designed to run no higher than their maximum safe speed. The motor also has mechanical speed limitations, as well as electrical limitations.

As a practical matter, when a fan system is “turned down” the horsepower required to operate the fan decreases at a greater rate than the horsepower generation of the motor. The torque required to operate the fan also decreases, while the motor’s torque remains constant. When a fan system is “sped up” the motor horsepower and torque increase until it reaches its design speed. Beyond that point the horsepower and torque required to operate the fan may exceed the limitations of the motor unless the motor is originally sized for maximum speed up conditions.

Example:

A system is controlled by a building management system that varies the volume of air delivered based on building load. The “peak load” point of operation is 7,000 CFM at 10.0” WG while the “part load” point of operation is 5,000 CFM at 5” WG.

Using Fan to Size, first select a fan/motor that will meet the “peak load” requirement. A Size 18 CA Plenum Fan operating at 18.57 BHP and 3331 RPM is selected. The motor selected will be 20HP at the synchronous speed of 3600 RPM.

Next, the design is checked using the “part load” conditions and the same Size 18 fan. At “part load” the fan requires 6.64 BHP at 2364 RPM. This is a good point on the operating curve and is a reasonable turn down.

Finally we compare the fan’s maximum safe speed (MSS) with the operating speed of the motor. A Size 18 CA Plenum Fan has a MSS of 3660 RPM. The nominal speed of a 20HP 3600 RPM motor is approximately 3520 RPM. A simple by-pass in the VFD may be used if necessary.

# CUBE ARRAY PLENUM DIMENSIONS

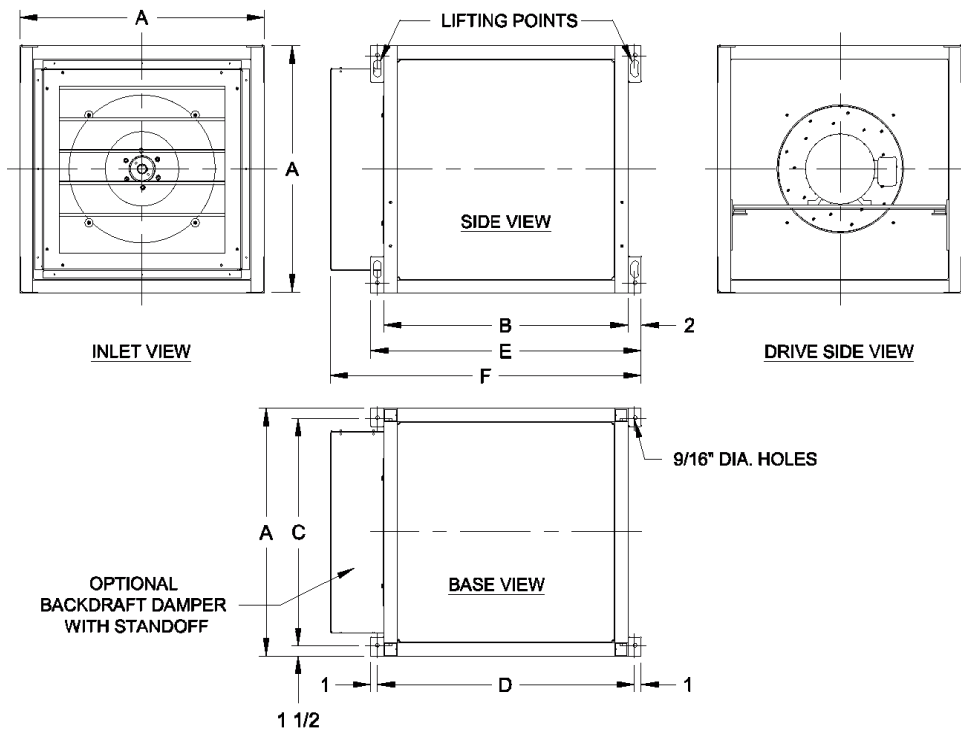

## DIMENSIONS

SIZE	FRAME	WHEEL MAX SAFE SPEED	WHEEL WR <sup>2</sup> (LBS-FT <sup>2</sup> )	CUBE DIMENSIONS (INCHES)						MAX MOTOR LENGTH	CUBES MAX STACK HEIGHT	WEIGHTS (LBS)		
				A	B	C	D	E	F			WHEEL	BARE FAN (LESS MOTOR)	FAN WITH DAMPER (LESS MOTOR)
13	143T/145T	4330	1.9	29	27	26	29	31	37 1/8	18 1/2	4	12	135	150
	182T/184T												135	150
15	143T/145T	3800	2.9	33	31	30	33	35	41 1/8	21 7/8		14	165	185
	182T/184T									21 7/8			165	185
	213T/215T									21 7/8		175	195	
16	143T/145T	3960	3.9	35	35	32	37	39	45 1/8	24 1/2		18	190	210
	182T/184T									24 1/2	190		210	
	213T/215T									25	200		225	
	254T/256T									25	210		230	
18	143T/145T	3660	6.1	37	37	34	39	41	47 1/8	25 1/8	21	210	235	
	182T/184T									25 1/8		210	235	
	213T/215T									25 3/8		220	245	
	254T/256T									25 3/8		230	255	
	284TS/286TS									25 3/8		230	255	
20	143T/145T	3390	9.5	39	39	36	41	43	49 1/8	25 7/8	3	31	235	265
	182T/184T									25 7/8			235	265
	213T/215T									26 7/4			250	275
	254T/256T									26 1/4			260	285
	284TS/286TS									26 1/4			260	290
22	143T/145T	3130	14.4	43	43	40	45	47	53 1/8	28 1/8	36	275	305	
	182T/184T									28 1/8		275	310	
	213T/215T									28 1/2		290	320	
	254T/256T									29		300	330	
	284TS/286TS									28 1/2		300	335	
	284T/286T									29		300	335	

# COMPLETE SELECTION OF AIR-MOVING EQUIPMENT

The New York Blower Company offers thousands of different types, models, and sizes of air-moving equipment. Contact your nyb representative for assistance in identifying the best fan for your application.

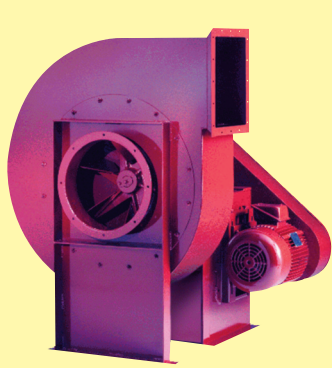

## DUST/MATERIAL HANDLING

Wide range of duty available with unique fan lines capable of handling light dust to heavy material. Typical applications include dust-collection and high-pressure process along with material-conveying.

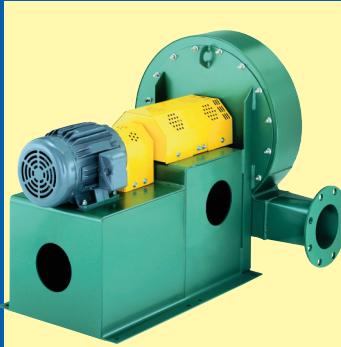

## AIR-HANDLING [CENTRIFUGAL]

Designed for clean to moderately dirty gas streams. Commercial and industrial HVAC, process cooling, light material-conveying, heat removal, and dryer exhaust are just a few of the numerous sample applications

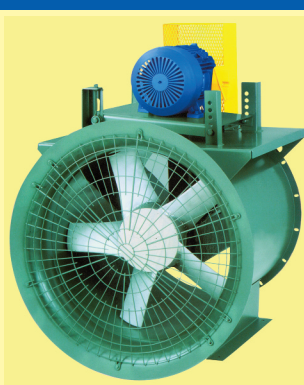

## AIR-HANDLING [AXIAL]

For the ideal handling of clean to moderately dirty airstreams. Commercial and industrial HVAC, drying and cooling systems, fume extraction, and process-heat removal are typical applications.

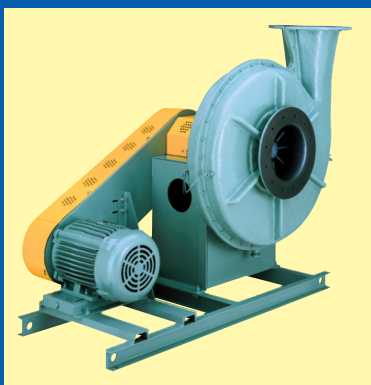

## FIBERGLASS REINFORCED PLASTIC [FRP]

Choice of performance and duty for corrosive gas streams. Applications include chemical process, wastewater treatment, laboratory hood exhaust, and tank aeration.

## CUSTOM PRODUCTS

Designed for unique applications. Variety of configurations, temperatures, flows, and pressures. Wide range of modifications and accessories are available to meet the most demanding specifications.

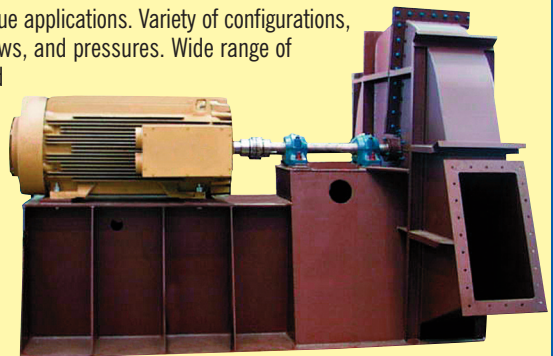

# Leading the industry forward since 1889

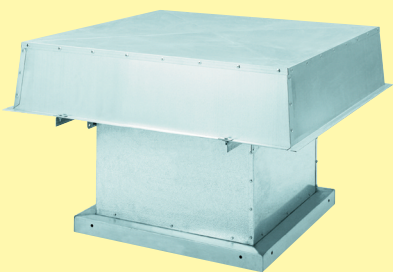

## ROOF VENTILATORS

Including both hooded and upblast ventilators, propeller fans, and centrifugal roof exhausters. These units are ideal for industrial, commercial, and institutional applications.



## HEATING PRODUCTS

Industrial-duty steam unit heaters with steam heating coils are available for facility heating and process-heat transfer.

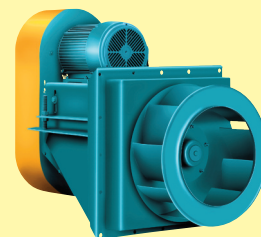

## PROCESS/FAN COMPONENTS

Plug fans, plenum fans, wheels, inlet cones, and housings for a wide variety of OEM applications. Process/fan components are used in air-handling units, ovens, dryers, freezer tunnels, and filtration systems.